

**RIVERS STATE UNIVERSITY OF SCIENCE AND TECHNOLOGY**

**NKPOLU, PORT HARCOURT, NIGERIA**

**EFFECTS OF PLANT DIETS ON SELECTED ASPECTS OF THE BIOLOGY OF  
SOME SPECIES OF PHLEBOTOMINE SANDFLIES (DIPTERA: PSYCHODIDAE)  
AND THE INFECTIVITY OF *LEISHMANIA MAJOR* YAKIMOFF AND  
*SCHOKHOR* 1914 (KINETOPLASTIDA: TRYPANOSOMATIDAE)**

**Mugunga Elie Muhinda,**

**Grad. Pharmacy & Biology (Hons), Lic. Zoology (Lovanium, Kinshasa).**

**THESIS SUBMITTED TO THE FACULTY OF SCIENCES IN FULFILMENT  
OF THE REQUIREMENTS FOR THE AWARD OF THE DOCTOR OF  
PHILOSOPHY DEGREE IN APPLIED ENTOMOLOGY OF RIVERS  
STATE UNIVERSITY OF SCIENCE AND TECHNOLOGY,  
PORT HARCOURT**

TH 577.1 (643) MUH

9250

**1994**

## DEDICATION

This work is dedicated to:

- My family

- My parents: Papa Fidelis M. Sebulimbwa  
&  
Maman Dorothea S. Kanziga

- My Masters: Professor Albert Bouillon  
&  
Professor Francis Hebrant

## DECLARATION

I Mugunga Elie Muhinda, hereby declare to the Senate of the Rivers State University of Science and Technology that the content of this thesis is the product of my personal and original work except where the reference has been acknowledged. It has not been submitted to any other University for any other or equivalent degree before.

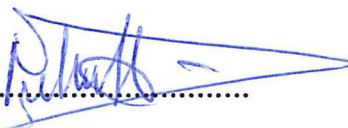
Signed  .....

Mugunga E. Muhinda

## CERTIFICATION

WE CERTIFY THAT THIS WORK WAS CARRIED OUT BY MUGUNGA ELIE MUHINDA AT THE INTERNATIONAL CENTRE OF INSECT PHYSIOLOGY AND ECOLOGY, NAIROBI, KENYA, UNDER OUR SUPERVISION.

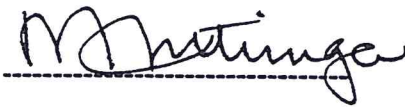

DR. MUTUKU J. MUTINGA

SENIOR PRINCIPAL RESEARCH SCIENTIST

ICIFE, NAIROBI, KENYA

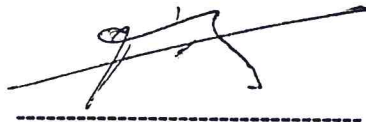

DR. M. BASIMIKE

RESEARCH SCIENTIST

ICIFE, NAIROBI, KENYA



DR. B.A. OKWAKPAM

SENIOR LECTURER

R.S.U.S.T, PORT HARCOURT, NIGERIA

## ACKNOWLEDGEMENTS

I would like to express my sincere gratitude to the Director of the International Centre of Insect Physiology and Ecology (ICIPE) and Chairman of the Academic Board of the African Regional Postgraduate Programme in Insect Science (ARPPIS), Professor Thomas R. Odhiambo, for giving me the opportunity to undertake this study within and through the mentioned institution and programme.

I thank Zairean authorities who helped me join ARPPIS and/or assisted me during my training. These are: Professor B.L. Lombeya, Minister for High Education and Scientific Research, Dr. N. Zana, Director General of The Centre de Recherche en Sciences Naturelles (C.R.S.N.), Dr. B. Balegamire, Scientific Director of the C.R.S.N., and Mr. M.O. Atenda and M. Katabana, respectively Ambassador and First Counsellor of the Zairean Embassy to Kenya.

I am grateful to the successive ARPPIS Coordinators, Drs M. Smalley, Z.T. Dabrowski and V.O. Musewe, the PESTNET Coordinator, Mr. A. Ondieki and the Training Officer, Miss R. Runo, for the administrative responsibility, material and moral support. My thanks go also to the Technician Miss V. Manene, and the members of ARPPIS Secretariat for the day-to-day assistance.

I am profoundly indebted to DSO of the Netherlands Government for granting me with financial support during my training.

My deep gratitude goes to the Programme Leader of the Medical Vectors Research Programme (MVRP), Dr. M.J. Mutinga for allowing me to complete the

study in the Programme and also I thank him along with Dr. M. Basimike for their guidance, advice and permanent encouragement as my ICIPE Supervisors. I am grateful to the members of the MVRP including (a) the Scientists Dr J. Kaddu, Dr. N.N. Massamba, Dr.C. Mutero, Dr. E. Asimeng, Mr. C. Chege, Mr. F. Amimo and Mr. D. Wachira, (b) the Technicians Mr. M. Nyamori, Mr. D. Omogo, Mr. J. Ndambuki, F. Kyai, Mr.B. Muia, P. Manywanda, Mrs E.M. Wahome, Miss M.C. Mukarugwiza, Mr. D.M. Mativo, and Mr. F. Masika, R. Mogaka and (c) the Secretaries Miss S. Kagondu and Miss I. Nzube for their assistance each in his/her specific area. I wish to thank my University Supervisor, Dr. B.A. Okwakpam for his guidance and remarks and through him the Authorities of the Rivers State University of Science and Technology (RSUST), Port Harcourt, for the acceptance of my candidature as a Ph.D student. My sincere thanks go to Professor H. Rembold (Max Plank Institute, Munich, FRG) for his suggestions and remarks and to Professor A. Hassanali and Dr. E. Osir for their scientific and technical assistance in the chemical aspect of the this study. In the laboratories of the two latter, I got a helpful collaboration from among others, Mr. E. Nyandat, Mr. D.O. Otieno, Mr. E. Rwekika in the Chemistry Laboratory and Mr. N. Ole Sitayo, Mr. D. Ogoy, Dr. H. Mahamat, and Mr. E. Kinyua, to them and others not mentioned I express my gratitude. Through Mr. M. Malonza, I thank the Livestock Ticks Programme for technical assistance. I express my gratitude to Dr. Nguya K. Maniania and all the lecturers of ARPPIS 1990 for refreshing scientific materials that I needed for the completion of the present work.

I feel deeply indebted to Mr. S.G. Mathenge of the Botany Department, University of Nairobi, for his invaluable contribution in the identification of the test plants. My sincere thanks go to Mr. N. Nsubuga, Head of ICIPE Library and his collaborators for providing the needed information, to Dr J.P.Odero, Head of the Insect and Animal Breeding Unit (IABU) and his collaborators especially Mr P. Njoroge and Mr. J.N. Kagoya for supplying laboratory animals and/or allowing to use some specialised equipment. I am very grateful to Dr. A. Odulaja, Head of Biomathematics Research Unit, his predecessor Dr. S. Nokoe and their collaborators, namely Mr. D. Munyinyi, Mr. M. Akello, Mr. M. Gathoga; Mr. H. Meena, Mr. O. Okello and Mr. J. Mirangi for their assistance in experimental design, data analysis and other computer techniques. My profound gratitude goes to Mr. P. Lisamula for his great contribution to the illustration of this work.

I will remember with nostalgia my colleagues of ARPPIS 1990 Class who made up a tight unity and solidarity with a so wide cultural diversity. Particularly, I will not forget the hard period passed with other francophones namely Mr. D. Dakouo, Mr. S.K. Dossa and Mr. J.S. Kayitare, trying to adapt and fit into the new socio-cultural environment. Among other contemporary ARPPIS members I counted many friends including Mr. F.K. Sika, Miss A. Ngi-Song, Mr. S. Bengaly, Mr. J. Mbapila ... I thank these and those not mentioned here for their interaction and solidarity.

Last but not least, I thank God for always reviving my stamina and pray him to bless those who have been missing me for so long and keeping their hopes up, i.e. my dear wife I. M. Musanabwiza and our beloved children M.M. Mutega-Raba, D.M. Mutali and N.M. Mutumwashyo.

## ABSTRACT

Laboratory investigations were carried out to assess phytophagy and its effects on the biology of phlebotomine sandflies and their capacity to transmit *Leishmania* parasites.

Preliminary trials to determine the optimum working standards in terms of anthrone concentration, exposure period and duration, effect of sandfly species and/or sex and effects of diets on the feeding rate, led to the choice of 1.25% as the concentration (w/v) of anthrone reagent to detect the presence of sugar in the gut of sandflies exposed overnight to different test plants and controls (sucrose and water). During the trials experiments neither sandfly species and/or sex nor diet type showed a significant influence in relation with exposure period or duration.

Anthrone tests with *Sergentomyia ingrami* and *Phlebotomus duboscqi* fed on seven plant species and controls showed a high selectivity in each sandfly species towards different test plants. *S. ingrami* had the highest feeding rate on *Rumex usambarensis*, the lowest among the plants being on *Tagetes minuta* while no presence of sugar was detected in 288 flies dissected. *Phlebotomus duboscqi* had the highest preference for *Melia azedarach*, the lowest being for *T. minuta*, with 1 out of 288 flies exposed to water showing a positive reaction for sugar. In both sandflies species the two most preferred plants were *R. usambarensis* and *M. azedarach* which displayed along with sucrose (positive control) a feeding rate beyond 50 percent. Plant parts and age were found to significantly affect the feeding response due to physical and/or physiological state of plant materials.



As for the feeding performance with reference to carbohydrates expressed by the blue colour intensity of the reaction between anthrone and sugar in the sandfly gut, the number of the flies exhibiting a low level sugar content (faint blue) was higher than the sum of those with intermediate level (medium blue stain intensity) and high level (deep blue stain intensity). And the distribution of different levels was significantly different according to individual diets. For instance *S. ingrami* was found with more sugar from *R. usambarensis* and sucrose while in *P. duboscqi*, the highest level was more important with *M. azedarach*, sucrose and *R. usambarensis*. In general there was a correlation between the feeding rate and the feeding performance.

The diversity in the feeding response by the test flies to the different test plants raised the question as whether there is any correlation between the feeding rate of the flies and the sugar content in the different plants. The results of anthrone test and spectrophotometry used to estimate the concentration of sugars in each plant did not reveal any correlation. It was rather noted that plants with a mild (*Azadirachta indica*) or poorest feeding rate (*T. minuta*) could be associated with the highest sugar concentration. In contrast bioassay tests effected to determine the behavioural response by *P. duboscqi* to olfactory stimuli from some test plants indicated a close relationship between the feeding and behavioural responses: plants with the higher feeding rate (*R. usambarensis*, *M. azedarach*) attracted much more flies than those with lower feeding rate (*Ocimum suave*, *T. minuta*).

After a blood meal to induce oogenesis, *S. ingrami* and *P. duboscqi* females were maintained on *R. usambarensis*, *S. incanum*, sucrose and water, respectively in order to evaluate the effect of these different diets on the fecundity and reproductivity of the test flies on one hand and the developmental duration and survival of larval and pupal stage of their progeny on the other hand. In both sandfly species, *R. usambarensis* and sucrose were associated with more or less significantly higher fecundity and reproductivity as compared with *Solanum incanum* and water. But, life cycle and survival in immature stages of the progeny were not significantly affected by the difference in mother's diet.

Longevity in *S. ingrami* and *P. duboscqi* maintained on *R. usambarensis*, *S. incanum*, sucrose and water (without a previous blood meal for females) as established by checking daily mortality in each batch and for each diet until the last fly died. In two sandfly species, the longest life span was recorded in the batches maintained on *R. usambarensis* or sucrose *S. incanum* and water were associated with the lowest longevity.

Development and quality of *L. major* (ICIZE 226) parasites were assessed in *P. duboscqi* maintained on *R. usambarensis*, *S. incanum*, sucrose and water after an infective blood meal from an infected BALB/c mouse. From the 4th day (incubation period) after the infective meals flies were dissected, infection recorded and location and motility of promastigotes observed in the different regions of the sandfly midgut. Higher infection rate, location in the foregut and movement of promastigotes towards the mouthparts were observed more frequently in those flies maintained on *R. usambarensis* or sucrose as compared to those maintained on *S. incanum* or water.

## TABLE OF CONTENTS

<b>CONTENTS</b>	<b>Page</b>
Title.....	i
Dedication.....	ii
Declaration.....	iii
Certification.....	iv
Acknowledgements.....	v
Abstract.....	viii
Table of Contents.....	xi
List of Figures.....	xviii
List of Plates.....	xx
List of Tables .....	xxii
List of Appendices.....	xxix
<b>CHAPTER 1: INTRODUCTION.....</b>	<b>1</b>
1.1 Definition of Leishmaniasis.....	1
1.2 Clinical forms.....	1
1.3 Distribution and importance .....	2
1.4 Control and prospects.....	5
1.4.1 Control.....	5
1.4.2 Prospects.....	8

<b>CHAPTER 2: LITERATURE REVIEW.....</b>	<b>14</b>
2.1 Insect-plant interaction.....	14
2.1.1 Plant resources and insect requirements.....	14
2.1.2 Insect reward to the plant.....	17
2.1.3 Host-plant finding and acceptance by insects.....	18
2.1.4 Insect adverse effect and plant resistance.....	25
2.1.5 Insect-plant interaction as a potential for pest control.....	28
2.2 Carbohydrates in insects.....	29
2.2.1 Importance of carbohydrates in insect life processes.....	29
2.2.2 Potential sources of carbohydrates for insects in nature...31	
2.2.3 Carbohydrates and phytophagy in sandflies.....	34
2.2.4 Carbohydrates and plant diets in sandfly biology.....	44
2.2.5 Carbohydrates and plant diets in <i>Leishmania</i> infectivity.....	46
2.2.6 Potential adverse effect of carbohydrates and phytophagy to sandflies and <i>Leishmania</i> .....	48
<b>CHAPTER 3: MATERIALS AND METHODS.....</b>	<b>50</b>
3.1 <b>Materials and experimental conditions.....</b>	<b>50</b>
(1) The test plants.....	50
(2) The test insects.....	60
(3) The test parasite.....	62
(4) The experimental animals.....	63
(5) The feeding cages.....	67

(6)	Anthrone reagent and microtiter plate.....	70
(7)	Materials and chemicals for assessment and estimation of sugar content in plant materials.....	72
(8)	Apparatus for assessment of attractancy/repellency.....	73
(9)	Individual oviposition vial.....	77
(10)	Moisture keeping system.....	77
(11)	Materials for monitoring biological events reading chemical reaction.....	80
(12)	Materials for monitoring experimental conditions.....	80
<b>3.2</b>	<b>Methods.....</b>	<b>82</b>
<b>3.2.1</b>	<b>Phytophagy of <i>S. ingrami</i> and <i>P. duboscqi</i></b>	
	offered various plant species.....	82
<b>3.2.1.1</b>	Standardisation experiments.....	82
<b>3.2.1.2</b>	Feeding <i>S. ingrami</i> and <i>P. duboscqi</i> on different plant species.....	84
<b>3.2.3</b>	Estimation of sugar content in the test plants.....	85
<b>3.2.3.1</b>	Water extracts from test plants.....	86
	Direct water extraction of fresh plant materials.....	86
	Water extracts from plant materials subjected to sequential extraction.....	86

3.2.3.2	Sugar standard solutions for standard curves.....	88
3.2.3.3	Anthrone test and spectrophotometry.....	89
3.2.3.4	Estimation of sugar concentration in water extracts from the test plants .....	89
3.2.4	Bioassay for assessment of attractancy/repellency of some of the plants tested for sandfly phytophagy.....	90
3.2.5	Effects of plant diets on sandfly biology.....	92
3.2.5.1	Fecundity, life cycle, developmental survival and reproductivity.....	92
3.2.5.2	Longevity.....	95
3.2.6	Assessment of the effect of plant diets and <i>Leishmania</i> parasite infectivity.....	96
3.2.7	Data processing and analysis.....	97
<b>CHAPTER 4: RESULTS AND DISCUSSIONS.....</b>		<b>98</b>
4.1	Phytophagy.....	98
4.1.1	Standardisation experiments.....	98
4.1.1.1	Anthrone concentration.....	98
4.1.1.2	Exposure time.....	100
4.1.1.3	Feeding preference.....	108
4.1.1.4	Discussion.....	112
4.1.2	Feeding rate and performance with reference to carbohydrates in <i>S. ingrami</i> and <i>P. duboscqi</i> offered different plant species, sucrose and water.....	114

4.1.2.1	<i>S. ingrami</i> .....	114
4.1.2.2	<i>P. duboscqi</i> .....	120
4.1.2.3	Discussion.....	126
4.2	Sugar content in the test plants.....	129
4.2.1	Anthrone test and spectrophotometry.....	129
4.2.1.1	Standard sugars.....	132
4.2.1.2	Water extracts.....	132
4.2.2	Sugar concentration.....	136
4.2.2.1	Sugar concentration in water extracts by direct extraction from fresh plant materials.....	139
4.2.2.2	Sugar concentration in extracts from the water phase of sequential extraction.....	154
4.2.3	Discussion.....	157
4.3	Behavioural response by <i>P. duboscqi</i> to olfactory stimuli from <i>M. azedarach</i> , <i>O. suave</i> , <i>R. usambarensis</i> and <i>T. minuta</i> .....	162
4.3.1	Plants tested against control.....	162
4.3.2	Plant versus plant bioassay.....	162
4.3.3	Discussion.....	168
4.4	Effects of plant diets on sandfly biology.....	170
4.4.1	Fecundity, life cycle, developmental survival and reproductivity.....	170

4.4.1.1	<i>S. ingrami</i> .....	170
4.4.1.2	<i>P. duboscqi</i> .....	179
4.4.1.3	Discussion.....	190
4.4.2	Longevity.....	194
4.4.2.1	<i>S. ingrami</i> .....	194
4.4.2.2	<i>P. duboscqi</i> .....	198
4.4.2.3	Discussion.....	202
4.5	<i>Leishmania</i> infectivity.....	203
4.5.1	Infection rate.....	203
4.5.2	Location and quality of parasites as an indication of transmission potential.....	206
4.5.3	Discussion.....	213
<b>CHAPTER 5: GENERAL CONCLUSION.....</b>		<b>217</b>
5.1	Phytophagy.....	217
5.2	Sugar content in the test plants.....	217
5.3	Bioassay for assessing the behavioural response by <i>P. duboscqi</i> to olfactory stimuli from some plant species previously tested for phytophagy.....	218
5.4	Effects of plant diets on sandfly biology.....	218
5.5	Plant diets and <i>Leishmania</i> infectivity .....	219



<b>CHAPTER 6: SUMMARY OF THE MAIN FINDINGS AND SUBSEQUENT</b>	
<b>QUESTIONS IN THE STUDIED AREA.....</b>	<b>220</b>
<b>6.1 Findings.....</b>	<b>220</b>
<b>6.2 Outstanding questions.....</b>	<b>221</b>
<b>REFERENCES CITED.....</b>	<b>223</b>
<b>APPENDICES.....</b>	<b>249</b>

## LIST OF FIGURES

- Figure 1a-b** Feeding rate of *S. ingrami* and *P. duboscqi* on sucrose (a) and *R. usambarensis* (b) through a 24-hour exposure with a 1-hour dissection interval.....104
- Figure 2a-b** Feeding rate on sucrose and *R. usambarensis* by *S. ingrami* (a) and *P. duboscqi* (b) through a 24-hour exposure with am 1-hour dissection interval .....105
- Figure 3a-b** Feeding rate in both sexes of *S. ingrami* fed on sucrose (a) and *R. usambarensis* (b) through a 24-hour exposure with a 1-hour dissection interval.....106
- Figure 4a-b** Feeding rate in both sexes of *P. duboscqi* on sucrose (a) and *R. usambarensis* (b) through a 24-hour exposure period with a 1-hour dissection interval.....107
- Figure 5** Feeding rate of *S. ingrami* on various plant species, sucrose and water.....115
- Figure 6** Feeding rate of *P. duboscqi* fed on various plant species, sucrose and water.....121
- Figure 7a-b** Curves drawn by plotting observed optical densities (spectrophotometry at 630 nm) against the corresponding concentrations of the standard sugars tested with cold and hot anthrone.....137

<b>Figure 8a-b</b>	Regression lines drawn from computed optical densities plotted against the corresponding concentrations of standard sugars tested with cold and hot anthrone.....	138
<b>Figure 9a-b</b>	Differential response by <i>P. duboscqi</i> to olfactory stimuli from <i>M. azedarach</i> (a) and <i>T. minuta</i> (b) tested against an artificial plant as a control through increasing exposure duration.....	167
<b>Figure 10</b>	Survival rate, with reference to eggs, of developmental stages of the progeny when <i>S. ingrami</i> mother females were maintained on different diets during the pre-oviposition period.....	177
<b>Figure 11</b>	Survival rate, with reference to eggs, of developmental stages of the progeny when <i>P. duboscqi</i> mother females were maintained on different diets during the pre-oviposition period.....	187
<b>Figure 12</b>	Cumulative adult mortality of <i>S. ingrami</i> maintained on <i>R. usambarensis</i> , <i>S. incanum</i> , sucrose and water.....	197
<b>Figure 13</b>	Cumulative adult mortality of <i>P. duboscqi</i> maintained on <i>R. usambarensis</i> , <i>S. incanum</i> , sucrose and water.....	201

## LIST OF PLATES

<b>Plates 1-7</b>	The test plants.....	53
<b>Plates 8a-b</b>	The test insects.....	61
<b>Plate 9</b>	Feeding <i>P. duboscqi</i> on a hamster as a source of blood meal for oogenesis.....	65
<b>Plate 10</b>	Feeding <i>P. duboscqi</i> on <i>Leishmania major</i> infected BALB/c mouse as a source of infective blood meal.....	66
<b>Plate 11</b>	Feeding cage for sugar or water.....	68
<b>Plate 12</b>	Feeding cage for plants.....	69
<b>Plate 13</b>	Microtiter plate with anthrone test showing different levels of blue colour intensity.....	71
<b>Plate 14</b>	Diagram of the apparatus designed to carry out tests on behavioural response on phlebotomine sandflies to olfactory stimuli from different test plants.....	77
<b>Plate 15</b>	Set-up for assessment of behavioural response by <i>P. duboscqi</i> to odours from different test plant using the apparatus described in Plate 14.....	76

<b>Plate 16</b>	Individual oviposition vial designed especially with provisions for permanent moisture and renewable diet supply.....	78
<b>Plate 17</b>	Set-up of humidity keeping system for individual sandfly females oviposition.....	79
<b>Plate 18</b>	Diagram showing the partition of sandfly gut.....	207
<b>Plate 19.</b>	Sluggish and dead-looking <i>L. major</i> promastigotes in the gut of <i>P. duboscqi</i> maintained on water after infective blood meal.....	212

## LIST OF TABLES

<b>Table 1</b>	Feeding rate of <i>S. ingrami</i> on sucrose as detected by three concentrations of cold anthrone.....	99
<b>Table 2</b>	Feeding rate of <i>S. ingrami</i> after a daytime and overnight exposure to sucrose.....	101
<b>Table 3</b>	Feeding rate of <i>S. ingrami</i> after a daytime and overnight exposure to <i>R. usambarensis</i> .....	101
<b>Table 4</b>	Feeding rate of <i>P. duboscqi</i> after a daytime and overnight exposure to sucrose.....	102
<b>Table 5</b>	Feeding rate of <i>P. duboscqi</i> after a daytime and overnight exposure to <i>R. usambarensis</i> .....	102
<b>Table 6</b>	Feeding rate of <i>S. ingrami</i> and <i>P. duboscqi</i> when both were offered either sucrose or <i>R. usambarensis</i> .....	109
<b>Table 7</b>	Feeding rate of <i>S. ingrami</i> and <i>P. duboscqi</i> when each was offered sucrose and <i>R. usambarensis</i> .....	110
<b>Table 8</b>	Feeding rate by sex when <i>S. ingrami</i> and <i>P. duboscqi</i> were given sucrose and <i>R. usambarensis</i> .....	111
<b>Table 9</b>	Feeding rate of <i>S. ingrami</i> on different parts of <i>S. incanum</i> ...	116
<b>Table 10</b>	Overall feeding performance of <i>S. ingrami</i> on different plant species and sucrose (all diets pooled together).....	118

<b>Table 11</b>	Feeding performance by diet in <i>S. ingrami</i> fed on different plant species and sucrose (individual diet).....	119
<b>Table 12</b>	Feeding rate of <i>P. duboscqi</i> offered young and old leaves of <i>M. azedarach</i> .....	122
<b>Table 13</b>	Feeding rate of <i>P. duboscqi</i> given different parts of <i>S. incanum</i> .....	122
<b>Table 14</b>	Overall feeding performance of <i>P. duboscqi</i> on different plant species and sucrose (all diets pooled together).....	124
<b>Table 15</b>	Feeding performance of <i>P. duboscqi</i> fed on different plant species and sucrose (by individual diet).....	125
<b>Table 16</b>	Optical density (spectrophotometry at 630 nm) of standard sugars with increasing concentrations.....	130
<b>Table 17</b>	Effect of sugar type on the optical density measured after test of different concentrations with cold and hot anthrone.....	131
<b>Table 18</b>	Effect of temperature on the sensitivity of individual standard sugar to anthrone test.....	131
<b>Table 19</b>	Optical density of water extracts from fresh plant materials after test with cold and hot anthrone.....	133
<b>Table 20</b>	Effect of temperature on the sensitivity of water extracts from fresh plant materials to anthrone reagent.....	134

<b>Table 21</b>	Optical density of water extracts from plant materials after sequential extraction and test with hot anthrone.....	135
<b>Table 22</b>	Mean concentration (w/w) in fructose equivalent by plant species for each temperature.....	140
<b>Table 23</b>	Overall mean concentration (w/w) in fructose equivalent for each temperature.....	141
<b>Table 24</b>	Mean concentration (w/w) in glucose equivalent plant species for each temperature.....	143
<b>Table 25</b>	Overall mean concentration (w/w) in glucose equivalent for each temperature.....	144
<b>Table 26</b>	Mean concentration (w/w) in sucrose equivalent y plant species for each temperature.....	146
<b>Table 27</b>	Overall mean concentration (w/w) in sucrose equivalent for each temperature.....	147
<b>Table 28</b>	Overall mean concentration (w/w) in fructose, glucose and sucrose equivalents for all the test plants after test with cold anthrone.....	149
<b>Table 29</b>	Mean concentration (w/w) in fructose, glucose and sucrose equivalents by plant species after test with cold anthrone.....	150
<b>Table 30</b>	Overall mean concentration (w/w) in fructose, glucose and sucrose equivalents for all the test plants after test with hot anthrone.....	152



<b>Table 31</b>	Mean concentration in fructose, glucose and sucrose equivalents by plant species after test with hot anthrone.....	153
<b>Table 32</b>	Mean concentration (w/w) by each sugar equivalent in all the test plants after sequential extraction and test with hot anthrone.....	155
<b>Table 33</b>	Mean concentration (w/w) of each sugar equivalent in each plant species after sequential extraction and test with hot anthrone.....	156
<b>Table 34</b>	Differential response by <i>P. duboscqi</i> to olfactory stimuli from different plant species with an artificial plant as a control.....	164
<b>Table 35</b>	Behavioural response by <i>P. duboscqi</i> to olfactory stimuli from different plant species tested against one another.....	165
<b>Table 36</b>	Differential response by <i>P. duboscqi</i> to olfactory stimuli from different plants species tested against a control with reference to increasing exposure duration.....	166
<b>Table 37</b>	Fecundity of <i>S. ingrami</i> females maintained on different diets during the pre-oviposition period.....	171
<b>Table 38</b>	Developmental duration (days) of larval and pupal stages of the progeny from <i>S. ingrami</i> females maintained on different diets during the pre-oviposition period.....	173

<b>Table 39</b>	Duration of the main stages of the life cycle in <i>S. ingrami</i> when the females were maintained on different diets during the pre-oviposition period.....	174
<b>Table 40</b>	Survival of the mother females and developmental stages of the progeny in <i>S. ingrami</i> when the former were maintained on different diets during the pre-oviposition period.....	176
<b>Table 41</b>	Reproductivity of <i>S. ingrami</i> females and sex-ratio of the progeny when the former were maintained on different diets during the pre-oviposition period.....	178
<b>Table 42</b>	Fecundity in <i>P. duboscqi</i> females maintained on different diets during the pre-oviposition period.....	180
<b>Table 43</b>	Developmental duration (days) of larval instars and pupal stage of the progeny from <i>P. duboscqi</i> females were maintained on different diets during the pre-oviposition period.....	182
<b>Table 44</b>	Duration of the main stages/periods in the life cycle of <i>P. duboscqi</i> when females were maintained on different diets during the pre-oviposition period.....	183
<b>Table 45</b>	Developmental survival during the larval stage of the progeny in <i>P. duboscqi</i> when females were maintained on different diets during the pre-oviposition period.....	185

<b>Table 46</b>	Survival of females and developmental stages of the progeny in <i>P. duboscqi</i> when the former were maintained on different diets during the pre-oviposition period.....	186
<b>Table 47</b>	Reproductivity of <i>P. duboscqi</i> females and sex-ratio of the progeny when the former were maintained on different diets during the pre-oviposition period.....	189
<b>Table 48.</b>	Longevity (days) in adults of <i>S. ingrami</i> maintained on different diets.....	195
<b>Table 49</b>	Cumulative mortality (quantile method) in adults of <i>S. ingrami</i> maintained on different diets.....	196
<b>Table 50</b>	Longevity (days) in adults of <i>P. duboscqi</i> maintained on different diets.....	199
<b>Table 51</b>	Cumulative mortality (quantile method) in adults <i>P. duboscqi</i> maintained on different diets.....	200
<b>Table 52</b>	Record of infection by <i>L. major</i> to <i>P. duboscqi</i> females maintained on different diets after infective blood meal.....	204
<b>Table 53</b>	<i>L. major</i> infection rate in <i>P. duboscqi</i> maintained on different diets after infective blood meal.....	205
<b>Table 54</b>	Location of <i>L. major</i> promastigotes in the gut of <i>P. duboscqi</i> maintained on <i>R. usambarensis</i> after infective blood meal.....	208

<b>Table 55</b>	Location of <i>L. major</i> promastigotes in the gut of <i>P. duboscqi</i> maintained on <i>S. incanum</i> after infective blood meal.....	209
<b>Table 56</b>	Location of <i>L. major</i> promastigotes in the gut of <i>P. duboscqi</i> maintained on sucrose after infective blood meal.....	210
<b>Table 57</b>	Location of <i>L. major</i> promastigotes in the gut of <i>P. duboscqi</i> maintained on water after infective blood meal.....	211

## LIST OF APPENDICES

<b>Appendix 1</b>	Feeding rate of <i>S. ingrami</i> on different plant species, sucrose and water.....	249
<b>Appendix 2</b>	Feeding rate of <i>P. duboscqi</i> on different plant species, sucrose and water.....	250
<b>Appendix 3</b>	Effect of specific diet on the feeding performance of <i>S. ingrami</i> on different plant species and sucrose.....	251
<b>Appendix 4</b>	Effect of specific diet on the feeding performance of <i>P. duboscqi</i> on different plant species and sucrose.....	251
<b>Appendix 5</b>	Effect of temperature on the optical density of three standard sugars after test with anthrone.....	252
<b>Appendix 6</b>	Effect of plant species on sugar concentration in water extracts from fresh plant materials tested by cold anthrone....	252
<b>Appendix 7</b>	Effect of plant species on sugar concentration in water extracts from fresh plant materials tested by hot anthrone.....	253
<b>Appendix 8</b>	Effect of plant species on sugar concentration (three equivalents) in water extracts from plant materials subjected to sequential extraction and treated with hot anthrone.....	254

<b>Appendix 9</b>	Effect of diet on the developmental duration of the immature stage of the progeny of <i>S. ingrami</i> females maintained, on <i>R. usambarensis</i> , <i>S. incanum</i> , sucrose and water during the pre-oviposition period.....	255
<b>Appendix 10</b>	Effect of diet on the duration of the main developmental stages/periods in life cycle of <i>S. ingrami</i> when the mother females were maintained on <i>R. usambarensis</i> , <i>S. incanum</i> , sucrose and water during the pre-oviposition period.....	256
<b>Appendix 11</b>	Survival of developmental stages of the progeny with reference to eggs in <i>S. ingrami</i> when females were maintained on different diets during the pre-oviposition period.....	257
<b>Appendix 12</b>	Effect of diet on reproductivity of females and developmental survival of the progeny in <i>S. ingrami</i> when the former were maintained on <i>R. usambarensis</i> , <i>S. incanum</i> , sucrose and water during the pre-oviposition period.....	258
<b>Appendix 13</b>	Effect of diet on the developmental duration of immature stages of the progeny when <i>P. duboscqi</i> females were maintained on <i>R. usambarensis</i> , <i>S. incanum</i> ; sucrose and water during the pre-oviposition period.....	259

**Appendix 14** Effect of diet on the duration of the main stages/periods of the life cycle of *P. duboscqi* when females were maintained on *R. usambarensis*, *S. incanum*, sucrose and water during the pre-oviposition period.....260

**Appendix 15** Effect of diets on the developmental survival during the immature stage of the progeny in *P. duboscqi* when females were maintained on *R. usambarensis*; *S. incanum*, sucrose and water during the pre-oviposition period.....261

**Appendix 16** Effect of diet on the reproductivity of females and developmental survival of the progeny in *P. duboscqi* when the former were maintained on *R. usambarensis*; *S. incanum*; sucrose and water during the pre-oviposition period.....262

**Appendix 17** Survival of the developmental stages of the progeny with reference to eggs of *P. duboscqi* females maintained on different diets during the pre-oviposition period.....263

## CHAPTER 1

### INTRODUCTION

#### 1.1 Definition of Leishmaniasis

The term "leishmaniasis" encompasses a group of closely related protozoan diseases caused by various species of the genus *Leishmania* (Kinetoplastida: Trypanosomatidae) harboured by different animal reservoir groups such as primates, carnivores, hyraxes, edentates, and rodents (Heisch, 1963; Dolmatova et Demina, 1971; Lainson and Shaw, 1979; Mutinga, 1986; Ashford, 1988) and transmitted to man through the bite of different sandfly species of the genera *Phlebotomus* and *Lutzomyia* (Peters, 1979; Lewis, 1982, Killick-Kendrick, 1990). So far sandflies are the only known vectors of human leishmaniasis (Mutinga, 1991).

#### 1.2 Clinical forms.

Defined species of *Leishmania* occurring in man are associated with one of the three main types of leishmaniasis namely (1) the visceral leishmaniasis (Kala-azar) caused by *Leshmania donovani*, *L. infatum*, and *L. chagasi*; (2) the cutaneous leishmaniasis (Oriental sore) caused by *L. tropica*, *L. major*, *L. aethiopica* and *L. mexicana*; and (3) the mucocutaneous leishmaniasis (Espundia) caused by, *L. braziliensis* (Bray, 1974; Peters, 1979; Kaddu and Mutinga; Lewis and Ward, 1987; Lysenko and Beljaev, 1987; Ridley, 1987; Walton, 1987). Complications in the primary



forms may lead to the so called post-kala-azar dermal leishmaniasis (Rees and Kager, 1987) and diffuse cutaneous leishmaniasis (Griffiths, 1987; Lainson and Shaw, 1987), respectively.

The different clinical forms may present a more or less complex transmission web : (1) the anthroponotic leishmaniasis has man as sole vertebrate host and reservoir whereas zoonotic leishmaniasis is more permanently harboured by other vertebrates and can be incidentally transmitted to humans through a bite of a sandfly vector (Bray 1974; Lysenko and Beljaev 1987). In general, in the absence of specific treatment, visceral leishmaniasis ends up killing the victim whereas cutaneous leishmaniasis will leave the victim with skin damage and face disfigurement entailing permanent psychological sequelae. The fatal end by mucocutaneous leishmaniasis on the other hand would essentially result from the destruction of naso-pharyngeal mucus which impairs feeding and cause the victim to die through hunger (Molyneux and Ashford, 1983; Garnham, 1987; Griffiths, 1987; Mutinga, 1988).

### **1.3 Distribution and importance**

According to Lainson and Shaw (1987), *Leishmania* distribution is controlled by 3 isolating factors: (a) the sandfly gut, (b) the macrophage cells of vertebrate hosts and (3) environmental barriers controlling the distribution of sandfly vectors on one hand, and animal reservoirs on the other hand. But it is most likely that the more severe selective pressures on *Leishmania* populations take place in the sandfly gut where the

organisms undergo their developmental cycle involving the production of motile forms (promastigotes) which are bound to survive in different environments of the alimentary tract before and during the migration to the mouthparts (Killick-Kendrick, 1979; Schlein, 1986, 1993). According to these authors, geographical distribution of various *Leishmania* species is closely related to the range of their respective sandfly vectors. The major consequence of this relation is the tendency of the distribution of the disease to follow the grouping of *Leishmania* species into the two main distribution areas: the Old World (Africa, Asia, Europe), and the New World (America) (Bray, 1974; Ashford and Bettini, 1987; Lysenko and Beljaev, 1987; Shaw and Lainson, 1987). The latter workers summarised the distribution of the most important *Leishmania* species and complexes in the New and Old World into anthroponotic and zoonotic types: (a) the visceral leishmaniasis of the Old World caused by *L. donovani* sensu stricto (anthroponotic) and *L. infantum* (zoonotic), (b) visceral leishmaniasis of the New World caused by *L. chagasi* (zoonotic), (c) cutaneous leishmaniasis of the Old World caused by *L. tropica* sensu stricto (anthroponotic), *L. major* (zoonotic), *L. aethiopica* (zoonotic), *L. peruviana* (anthroponotic); (d) cutaneous leishmaniasis of the New World caused by *L. mexicana* complex (zoonotic), *L. braziliensis* complex (zoonotic).

The distribution of the main clinical forms of the disease and the vectors involved or suspected in both the Old and New World are outlined by several authors (Bray, 1974; Molyneux and Ashford, 1983, Lewis and Ward, 1987; Killick Kendrick, 1990). These include: (a) the visceral

leishmaniasis in the Old World is caused by *L. infantum* transmitted by *Phlebotomus ariasi* in South-Western France and *L. donovani* transmitted by *P. martini* in Kenya while in the New World *L. chagasi* is transmitted by *Lu. longipalpis* in South America; (b) *L. major* transmitted by *P. duboscqi* in Kenya and *L. mexicana* complex by *Lu. flaviscutella* complex in Central America are among the cases of cutaneous leishmaniasis in the Old and the New World, respectively.

The ability of sandfly species to survive under different ecological conditions such as the intense heat in the Sudan, the harsh cold in Peru (Garnham, 1987), the cave dwelling of Mont Elgon in Kenya (Mutinga, 1982), termite mounds, tree holes, animal burrows (Mutinga, 1991), at different vegetation heights (Basimike et al., 1989), various conditions of temperature, humidity and chemical content in the breeding sites (Basimike and Mutinga, 1990; Basimike et al., 1991) account for the spread of the disease worldwide. For these reasons, Garnham (1987) described leishmaniasis as a complex and cosmopolitan problem.

However, as late as 60 years ago (Garnham, 1987), leishmaniasis was considered to have a very limited distribution, covering only parts of India, China, Middle East, southern Europe, and South America; consequently it was given minor attention among tropical diseases. The situation has changed, the disease is found on all continents minus Australia and Antarctica (Garnham, 1987). The increasing evidence on the importance of the disease (Raadt de, 1986) justified its integration in 1976 into the target diseases of the UNDP/World Bank/WHO Special

Programme for Research and Training in Tropical Diseases (TDR)  
(Garnham, 1987).

Worldwide 350,000,000 people are exposed to leishmaniasis, 12,000,000 are infected and 400,000 cases occur annually (WHO, 1990). Moreover, extrapolation based on the available data led Walton (1988) to suggest an incidence as high as 1.5 to 2 million cases per year.

Besides its impact on public health, leishmaniasis is a very serious socio-economic problem (Leon, 1988), especially in the rural areas (Kaddu, 1981) where the increasing demand for land, search for water for domestic or economic use bring people to the areas occupied by the animal reservoirs and insect vectors of the disease (Mutinga, 1986).

## **1.4 Control and prospects**

### **1.4.1 Control**

#### **(a) Control of *Leishmania* parasites**

In his review on experimental chemotherapy, Neal (1987) remarked that study on chemotherapy of leishmaniasis had not attracted much interest in comparison with other diseases; this situation is reflected in the age of the currently used drugs. Indeed, he noted that the first-line drugs, i.e., the pentavalent antimonials (e.g. sodium stibogluconate and meglumine antimoniate), were introduced in 1947 and 1950, whereas the second-line ones, pentamidine (diamide) and amphotericin B (antibiotic) were introduced in 1940 and 1959, respectively.

On compiling data on the "therapy of leishmaniasis in man", Bryceson (1987) underscored some important factors affecting the outcome of treatment: (i) intracellular state of the parasite; (ii) cell-mediated immunity, (iii) nutritional status of the patient, (iv) severity of disease, (v) intercurrent state of the disease, and suitability of choice of treatment.

**(b) Control of sandfly vectors**

Vioukov (1987) reviewed the actual and potential methods for controlling transmission of leishmaniasis. As in many other vector-borne diseases, the control of sandfly vectors was the first strategy. Among the different methods, chemical control was the most important particularly because of the successful eradication of anthroponotic cutaneous leishmaniasis in the (1) the USSR (Republics of Central Asia and Transcaucasus), (2) Mediterranean, Middle and Far East countries and (3) focus of zoonotic leishmaniasis in Turkmenia. Several insecticides were tested, including DDT, BHC, dieldrin, malathion, chlorophos and others, but in most cases the first two proved most successful. Other methods tested or advised for vector control were: biological control, genetic control, and ecological control. Further aspects of transmission control reported and commented on by the author are: control of the parasites, control of reservoir hosts, and protection of people from infection. Trials using pyrethroid (permethrin)-impregnated curtains, bednets and wall cloth proved efficient in the control of insect-borne diseases, especially malaria and leishmaniasis (Curtis *et al.*, 1990; Mutinga *et al.*, 1992)

**(c) Results of parasite and vector controls**

Reports by different workers summarised by Vioukov (1987), show that various control measures have been used with the chemical approach being dominant (drugs against the parasite and insecticides against the vector). These methods yielded encouraging results. However, the spectacular results obtained at a trial in an area might be followed by disappointing ones at a subsequent trial in the same or different area. Failures in chemical control are mostly attributed to (i) relapse after adequate response (Wijers, 1971), resistance of *Leishmania* to pentavalent antimonials (Bryceson, 1987; Neal, 1987; WHO/TDR, 1991), cost and/or the potential toxicity of the second-line drug such as pentamidine and amphotericin B (Oster, 1986; Were *et al.*, 1986; Neal, 1987, WHO, 1991) and (ii) resistance of vectors to insecticides (Vioukov, 1987; WHO/TDR, 1990, 1991). Furthermore, a recent report (WHO, 1991) entitled "Kala-azar surges on two fronts" highlights the situation. One of the two fronts is the State of Bihar in India where one of the most important sandfly vector, *P. argentipes* was reported for the first time as resistant to DDT, soon after the discovery of large-scale failure of patients to respond to antimonial drugs (WHO/TDR, 1990). The other front was Bentiu region, Upper Nile Province, Southern-Sudan, where leishmaniasis was squarely termed the "killing disease"; accounting for 40,000 deaths in 5 years with 300,000-400,000 people exposed to infection in a total population estimated at less than one million.

The Bihar epidemic and the Bentiu scourge were similar to the crises in malaria control programmes in many countries, when the parasite no longer responded to drugs and the vector became resistant to insecticides (WHO/TDR, 1991).

#### **1.4.2 Prospects**

Considering this background, the future is far from bright, if one takes into account that results achieved by chemical control have continuously been challenged, especially since kala-azar struck again in India and new forms and new foci of leishmaniasis appeared in Africa, Central Asia, South America ( e.g., Amazonian Forest), etc. (Bryceson, 1987).

The complex character of the leishmaniasis makes it difficult to envisage a universal method to control the disease ( Bryceson,1987; Vioukov, 1987; Mutinga, 1988). Therefore, although chemotherapy and chemical control of vectors are still indispensable to reduce mortality and morbidity, and to curb epidemic outbreaks, respectively, the long-term plans should incorporate an integrated strategy based on a good understanding of all the factors likely to significantly influence transmission (Vioukov,1987; Bryceson, 1987; Kaddu, 1986; Mutinga,1988).

Among a variety of natural factors affecting the transmission of leishmaniasis, the relationships between insects and their host-plants have received particular attention (Strong *et al.*, 1984) while the plant-parasite relationship is a subject of a growing interest. That attention was probably

due to the fact that phytophagous insects represent at least one-quarter of all the living species while their host plants make up a second quarter, thus, phytophagous insects and their host-plants constitute at least one half of the entire community of living species (Strong *et al.*, 1984). These insects are certainly very important because of their involvement as pests of crop (Rabb *et al.*, 1984).

A host plant is meant to provide one or more of the essential resources for the insect: food and feeding site, mating site, egg-laying site, and/or refugia (Opp and Prokopy, 1986). Obviously, trophic relationships constitute an important aspect in insect-plant interactions. Indeed, being heterotroph, insects require exogenous proteins, lipids, carbohydrates, nucleic acids, vitamins, sterols, minerals etc., to achieve specific functions such as metabolism, development, growth, survival and reproduction (Chippendale, 1978; Hagen *et al.*, 1984;). Series of experiments have shown that plant allelochemicals attract insects for feeding (Robacker *et al.*, 1990; Metcalf and Metcalf, 1992) and oviposition (Tingle *et al.*, 1990).

While providing necessary nutrients for insect biological necessities, host plants have release substances that help them to resist attack and/or eventual over-exploitation by phytophagous animals, including insects. Plants produce various chemicals some of which are toxic (e.g., lectins), in various degrees, to plant pathogens, insects and mammals; other compounds (saponins, tannins, alkaloids, gossypol and other terpenoids) can serve, as oviposition repellents, anti-feedants, and growth and development inhibitors (Springer, 1986).



Positive and negative aspects of insect-plant interaction culminated in a growing practical interest on their potential for integrated pest management as shown by the following examples:

(a) Various types of traps associated with attractiveness of certain plants (alone or baited) have been tested for crop protection or monitoring of insect populations (Finch, 1986; Schlein *et al.*, 1987).

(b) *Ocimum suave* has proved efficient in repelling stored crop pests and mosquitoes (Chogo and Crank, 1981; Hassanali *et al.*, 1990) while *Solanum berthaultii* exhibited a dramatic mechanical and behavioural resistance to several pests, including the Colorado potato beetle (*Leptinotarsa decemlineata*) (Tingey, 1991).

(c) Other plants e.g. *Petunia* sp, though they are attractants and phagostimulants to various insects, including the tobacco cornworm (*Manduca sexta*) and *L. decemlineata*, exhibit a high toxicity and bioregulator activities on these insects (Elliger and Waiss, 1991).

(d) Some of the compounds involved in plant resistance to insects proved so powerful as toxicants and deterrents that they served as the basis for novel insecticides (Elliot *et al.* 1978; Rejesus, 1990; Green, 1991; Hedin, 1991).

(e) One of the breakthroughs in the investigation on the practical applications of insect-plant interaction as a potential for pest/vector control are the conclusive experiments on the Neem tree (*Azadirachta indica*), which demonstrated its properties of (i) disrupting or inhibiting the development of eggs, larvae and pupae, (ii) blocking the moulting of

larvae, (iii) disrupting mating and sexual communication; (iv) repelling larvae and adults from host plants, (v) deterring females from laying eggs, (vi) sterilising adults, (vii) poisoning larvae and adults, (viii) deterring feeding, (ix) blocking the ability to swallow (reducing the motility of the gut), (x) hindering metamorphosis at various stages and (xi) inhibiting the formation of the chitin in many insects species (Schmutterer and Zebitz, 1984; Schmutterer, 1987; Ishaaya, 1986; Hedin, 1991; Lee et al., 1991; Panel on Neem, 1992).

While exclusive phytophagous insects rely on plants as sole resources to meet their nutritional requirements, hematophagous insects use plant diets to supplement the blood meal from vertebrate hosts (Dolmatova and Demina, 1971; Schlein, 1986; Magnarelli, 1988). Along with proteins and lipids, carbohydrates are important components of insect diet (Chippendale, 1978) and is one of the main constituents of the plant sap (Auclair, 1963). In addition to their nutritional feature some carbohydrates have proven phagostimulants (Chippendale, 1978; Ishaaya, 1986; Kogan, 1986)

Like other hematophagous Nematocera, sandflies feed on sugars. Indeed, the presence of carbohydrates in the sandfly gut has been detected by chromatography (Lewis and Domoney, 1966) for various sugars and anthrone test for fructose and/or those with fructose moiety (Young *et al.*, 1980).

Although there is no doubt about the plant origin of sugars for insects as far as nectar and honeydew are concerned, the direct

procurement of carbohydrates from plant sap by piercing and sucking through plant tissues needs more supportive evidence. Indeed, some workers suggest that honeydew is the most likely source of sugars for sandflies, on the basis of the results of the tests using HPLC (High Performance Liquid Chromatography) and GC (Gas Chromatography) (Moore, 1987) which showed a similarity between the sugars from wild sandflies and the sugar constituents of honeydew (Killick-Kendrick, 1987; Moore *et al.*, 1987; MacVicker, *et al.*, 1990).

However, Schlein and Warburg (1986) demonstrated in laboratory experiments with *P. papatasi*, that sandflies selectively probe, pierce plant tissues and suck the sap in the same way as the blood feeding mode. Unfortunately, when Ashford (1974) had observed different sandfly species probing stems and leaves of various plants, in Ethiopia, there was no subsequent test for identification of sugars.

Different laboratory experiments have shown the effects of sugars on some biological aspects of sandflies such as fecundity, survival, and longevity (Chaniotis, 1974; Endris, 1984; Killick-Kendrick, 1987).

Furthermore, successful transmission of *L. donovani* by *P. argentipes* females fed on raisins in contrast to the lot denied sugar proved the role of carbohydrates in the vector competence of sandflies (Adler and Theodor, 1957). On the other hand, the location of *L. infantum* promastigotes were limited in the mid gut of *P. ariasi* females routinely fed on raisins whereas those flies infected, released and recaptured had parasites in the foregut, suggesting that plant sap contains in addition to

sugars, other components (Auclair, 1963) necessary for the transmission of parasites by bite (Schlein, 1986).

The current trend in the management of leishmaniasis is on the understanding of plant-sandfly-*Leishmania* relationship, which will contribute significantly to an integrated control programme.

The present study investigates the effects of plant diet on the biology of the sandflies and the transmission of *Leishmania* parasite.

It has three main objectives:

- 1- To demonstrate the phytophagy and evaluate the feeding rate and feeding performance of sandflies fed on various plant species;
- 2- To assess the effects of plant diets on selected aspects of sandfly biology (e.g., fecundity, life cycle duration, developmental survival, reproductivity and longevity);
- 3- To establish the foundation for the assessment of the effects of plant diets on *Leishmania* parasite infectivity.

## CHAPTER 2

### LITERATURE REVIEW

#### 2.1 Insect-plant interaction

##### 2.1.1 Plant resources and insect requirements.

The process of resource acquisition holds a central place within the context of insect-plant interaction; thus the habitat of an insect may be divided into resource and non-resource areas (Opp and Prokopy, 1986). Among the habitat's constituents, the plants provide essential resources including food, mating site, egg-laying site and/or shelter; the quality of these resources influences the insect activity and survival (Finch, 1986). Trophic relationships constitute a very important factor in insect-plant interaction. Kogan (1986) noted that in addition to the general basic nutritional requirements of all higher animals - with proteins, lipids and carbohydrates being the main classes of organic compounds (Chippendale, 1978), insects need an external source for the steroid nucleus. Apart from rare cases of autogeny, proteins and lipids are important in the deposition of yolk and the number of eggs laid per female insect (Engelmann, 1984). In addition to its role as energy reserve, lipid includes sterols which serve as building blocks for hormones and pheromones (Kevan and Baker, 1984). Other plant substances referred to

as phytohormones or growth regulating substances such as cytokinins, gibberelins, auxins, abscissic acid, etc., are known to play a significant role in complex plant bioprocesses directly or indirectly influencing development processes of insects (Scheurer, 1977). For example, ecdysone-like substances were reported to shorten the process of maturation of larvae of *Locusta migratoria migratorioides* and *Schistocerca gregaria*. Auxins and gibberelins increase protein synthesis in plants, thus controlling the production of amino acids and synthesis of RNA. The activation and metabolism of enzymes were influenced, while cytokinins delayed the decomposition of proteins and chlorophyll in isolated leaves. The general observation is that the use of growth regulators either stimulates or inhibits the development processes in the plant, resulting in the disturbed relationship between the plant and the pest (Kevan and Baker, 1984).

However, nutritional requirements of insects are qualitatively and quantitatively specific (Kogan, 1986). There is a defined ratio of protein to carbohydrate that must be maintained for optimum growth, survival and reproduction. For instance, larvae of the corn earworm, *Heliothis zea*, achieve better utilisation and conversion of digested food on a diet containing protein and carbohydrate at the proportion of 80:20 (Waldbauer and Friedman, 1991). More generally, many phytophagous insects are restricted in their range of host plants, although it is rather rare to find one insect species confined to one plant species. There is evidence that plants differ in the proportions of nutrients and a given insect may be adapted to a particular balance. Furthermore, it has been experimentally demonstrated

that nutritional value determines, at least in part, the acceptance or rejection of the host plant by insects. The same host selection occurs for the oviposition as illustrated in (i) *Papilio machaon* (Lepidoptera) preferring for oviposition species other than its usual host plant -*Angelica* (Umbelliferae); and (ii) the Colorado potato beetle, *Leptinotarsa decemlineata*, normally found on *Solanum tuberosum*, oviposits on a variety of solanaceous plants (Engelmann, 1984). At the other extreme, some insects have refined the host specificity to such an extent that they have evolved mechanisms to use as kairomones some toxins initially selected in plant for defence, which is another feature contributing to the success of various insect species (Hagen *et al.*, 1984; Engelmann, 1984).

Phytophagous insects exploit their hosts in different ways according to insect species and food type: some feed externally by biting and chewing, others by sucking through plant tissue or vascular system, some species mine into their host and a few form galls, etc. (Strong *et al.*, 1984). The most conspicuous and common feeding resource for phytophagous insects is the floral part of the plant. This particular relationship is emphasised by Kevan and Baker (1984): "The harmonies between insectan and floral adaptations are hard to separate, so interwoven are the structure, function, behaviour, physiology and chemistry of both insects and flowers that mutually assure reproductive success. The author also pointed out that on visiting flowers, insects expect (in terms of food) two types of rewards: (1) nectar and (2) pollen. Nectar is a complex mixture of chemicals, including sugars, amino acids, proteins, and lipids, antioxidants,

alkaloids, vitamins, organic acids, allantoin and allantoic acid, dextrans and inorganic materials such as minerals. Second to nectar is pollen which does not have the same range of constituents as nectar (e.g. free sugars are less important) but is nevertheless highly nutritive since it contains in adequate quantities proteins, peptides, amino acids and lipids. Hagen *et al.* (1984) found that for adult holometabolous insects including many Diptera and Hymenoptera, Coleoptera and Lepidoptera and hemimetabolous such as some Heteroptera, the main constituents of their natural food are floral nectar, extrafloral nectar, pollen and honeydew. These contain enough nutrients and other materials required to support development, growth and reproduction. While other constituents are of floral and/or nectary gland origin, honeydew is mainly excreted by aphids and coccids (Auclair, 1963; Brown, 1975).

### **2.1.2 Insect reward to the plant**

If the flower visiting insects are rewarded in terms of food, the visited plant is pollinated, thus ensuring reproduction. Kevan and Baker (1984) traced the phenomenon to late Jurassic and Cretaceous; when flowering plants became important, beetles were well differentiated, the reason why the latter are often considered the most primitive pollinators. Insects may play many other roles from which benefit plants (Huffaker *et al.*, 1984). Indeed, some insects mediate interspecific competition between other organisms, including plants, thus modulating their population dynamics.



### **2.1.3 Host-plant finding and acceptance by insects.**

Lewis and van Emden (1986) reported that most of the investigations dealing with insect-plant interactions had centered on the research and identification of chemicals important in insect feeding. The well-defined goals are: (a) to study the naturally occurring chemicals in the plant hosts of insects; (b) to determine the mechanisms of resistance in crop plants ; (c) to find anti-feedants for pest control; and (d) to increase feeding in artificial diets.

Insect feeding or oviposition on plants requires an encounter between the insect and the host plant ( Jermy, 1976): the host plant is perceived, found and accepted as an individual or preferred among a group. In other words, an insect faced with a variable population of hosts has to exhibit a double property: preference and performance (Singer, 1986). The same phenomenon was observed in laboratory bioassay systems using insect species against the extracts of their host and non-host plants (Mitchell *et al.*, 1990). The acceptance and preference result from a positive encounter, involving attraction as opposed to the negative encounter leading to repellency from a certain distance or deterrence after a close contact (Shorey, 1977; Singer, 1986). The actual feeding performance depends on the presence of phagostimulants as opposed to poor or non-feeding caused by the presence of feeding deterrents. It was demonstrated that in some lepidopterous species food preference may be induced from the early larval stage so that preference in later larval and adult stages are some times pre-conditioned (Ali, 1976; Hanson, 1976).

Results from experiments with African armyworm, *Spodoptera exempta*, showed different levels of perception and phagostimulation by various sugars which were then classified in the following decreasing order: D-fructose > sucrose > raffinose > maltose > glucose > melibiose > D-galactose; L-rhamnose and cyclohexitol m-inositol did not elicit any feeding activity. Auclair (1976) demonstrated that amino acids were optimally phagostimulant at the concentrations of 2.5 - 4.0% in the aphid *Acyrtosiphon pisum*, while a repellent/deterrent effect was observed at 5% and above; the optimum range for phagostimulation was reflected in optimum growth. Among the compounds that frequently deter insect feeding, are alkaloids, flavonoids, terpene lactones and phenols (Smith, 1989). However, a phagostimulant may or may not have a known nutritional value by itself; for example, sucrose is a nutrient and phagostimulant while sinigrin simply enhances feeding in some oligophagous insects which prefer Cruciferae: once applied to a neutral or an naturally non-preferred, without pronounced detergency, sinigrin triggers and sustains feeding (Dethier, 1976). The process of finding a plant on which to feed and/or oviposit is governed at each stage by an intricate array of sensory organs including those for vision (photoreceptors), olfaction and gustation (chemoreceptors); and tactile (thigmoreceptors) dispersed on the surface or located at specific areas (head, buccal cavity, antennae, mouthparts, tarsi, ovipositor) of the insect's body (Dethier, 1976; Hawkes and Coaker, 1976; Ma, 1976; Schoonhoven, 1977; Smith, 1989; Nottingham *et al.*, 1991). Olfactory and gustatory receptors receive stimuli

from volatile and non-volatile compounds produced by plants and referred to as allelochemicals (Hagen *et al.* 1984; Mitchell *et al.*, 1990). Dethier (1976) divided them into two groups: (a) the first group includes stimuli which orient toward the plant (attractants), or arrest (arrestants) locomotion in the proximity of the plant, or initiate and maintain feeding (phagostimulants), or oviposition (ovipositional stimulants), the second group comprises those stimuli that drive away from the plant (repellents), or prevent feeding (feeding deterrents) or oviposition (ovipositional deterrents). On the other hand, within their visual sensitivity spectrum of 300 nm (ultraviolet) - 700 nm (infrared), insects are attracted according to the hue, saturation and intensity of the colour with many species responding mainly in the range of yellow or yellow-green (500-580 nm) (Chaniotis, 1974; Finch, 1986; Smith, 1989). It has also been noted that visual and chemical stimuli are perceived simultaneously during orientation of insects to a potential plant: during long-range orientation, an insect may use vision for recognition of the shape of an object and utilise olfaction to perceive plant attractants (Smith, 1989). However, while investigating olfactory responses to distant plants and other odour sources, Kennedy (1977) remarked that little was known about how widespread and how utilised are distant olfactory responses are in nature. His remark was based on counts done as flying bark beetles and aphids came in to land on host and non-host plants. The experiments conducted under similar conditions resulted in landing at the same rate on both categories of plants. From these results Kennedy (1977) concluded that any chemical discrimination between host and non-

host begins only after a relatively indiscriminate visual landing response, and takes the simple form of either staying or leaving. This makes the chemosensory distinction between olfaction and taste inadequate at the behavioural level and appeals for further operational discrimination between close-range and distant olfactory responses. The latter category excludes points a few millimeters or even a few centimeters away from a source, but includes perhaps those at decimeters and certainly those that are meters away. It is therefore certain that oriented movements toward plant odour source from decimeters or further away, are cued by stimuli other than odour. This indicates that the latter would act by switching on or off, or otherwise regulating some non chemotactic movement toward the source e.g., orientation into wind (anemotaxis) .

It is therefore possible that insect responses to plant stimuli may be partly accommodated in Shorey's chemical and/or biological communication. Both concepts imply the release of one or more stimuli by an organism that influence the reaction by another organism, the benefit of the reaction going either to the emitter or to the receiver, or both. The chemicals involved in those reactions have been grouped in different ways. Hagen, *et al.* (1984) provided the following classification: (a) a chemical or a mixture of chemicals released from one organism and induces a response by an individual of the same species has been called pheromone; (b) a chemical or a mixture of chemicals that is released by one organism and induces a response in an individual of another species, which is beneficial to the receiver has received the name kairomone; (c) a chemical

or a mixture of chemicals that is released by one organism and induces a response in an individual of another species, which is beneficial to the emitter has been called an allomone; and (d) a chemical or a mixture of chemicals that is released by one organism and induces a response in an individual of another species, which is beneficial to both the emitter and the receiver has been termed a synomone. In a parallel system, Dethier *et al.*, (1976) listed six categories that encompass most behaviourally active chemicals: (a) a locomotory stimulant is a chemical that causes kinesis reaction which, in the absence of orientation cues often causes the animals to disperse from an area by increasing the speed of locomotion or appropriately affecting the rate of turning; (b) an arrestant is a chemical that causes kinesis reactions which in the absence of orientation cues, often cause the animals to aggregate near the chemical source by decreasing the speed of locomotion or appropriately affecting the rate of turning; (c) an attractant is a chemical that causes animals to make oriented movements toward its source; (d) a repellent is a chemical that causes animals to make oriented movements away from its source; (e) a feeding/mating/ovipositional stimulant is a chemical that elicits one of these behavioural reactions; and (f) a feeding/mating/ovipositional deterrent is a chemical that inhibits one of the behavioural reactions. Kennedy (1977) reviewed some of the technical terms used to describe those behavioural movements in a more conceptual way: (a) a kinesis describes a non-oriented response to stimuli (orthokinesis refers to any movement following a linear direction while klinokinesis describes turning movements). Kineses

are referred to as direct or inverse when movement or turning increases or decreases with the strength of the stimulus, respectively. (b) A movement which is oriented with reference to the source of the stimulus is termed taxis; when it is directed toward the source or away from the source, a taxis is called positive (response to an attractant) or negative (response to a repellent). However, the same worker noted that beside the locomotory responses elicited by chemical stimuli there are other cues for orientation from distant sources. These are orientation responses that are modulated by chemical stimuli but directing at the wind or other visual targets.

Several techniques have been used to assess insect host finding in nature and biological activity in laboratory (Dethier, 1976; Jermy, 1976). In nature the isotope  $^{32}\text{P}$  in mark-release-recapture proved appropriate in various situations (Hawkes and Coaker, 1976). Laboratory bioassays with olfactometers and electroantennograms have been performed to assess the insect response to various stimuli (Hawkes and Coaker, 1976), chromatography techniques to analyse the compounds of plant odours (Robacker *et al.*, 1990) and wind tunnels devised to evaluate the effect of different stimuli on insect flight (Tingle *et al.*, 1989, 1990). Finch (1986) summarised the most important advances accomplished in bioassay techniques for insect attractants with emphasis on visual and olfactory stimuli. Visual cues with various hues and their different degrees of saturation and intensity were assessed, using coloured papers, neutral papers, coloured lights, real plants, mimic plants and suspended angle. Olfactory stimuli were evaluated by different olfactometers, Y-tubes, small

arenas (for larvae), coupled electrophysiology/gas chromatography, and wind tunnels.

The results of attraction stimulated chemically and visually were measured by various traps including, visual traps, visual/chemical traps, chemical traps, etc. Zmur and Stary (1992) reported a successful experiment using pitfall traps baited with alpha-pinene, turpentine and fresh bark to trap coleopterans of the species *Hylobius abrietes* in a forest mainly composed of spruce (*Picea*) and Pine (*Pinus*).

The evaluation of acceptance/feeding was undertaken by different approaches, according to insect species, as summarised by Lewis and Emden (1986). For chewing insects, the amount of ingested material was measured directly (area or weight of substrate ingested) or indirectly (fecal production, feeding duration..). In sucking insects, the weight of sachets containing test diets and radioisotope technique were direct measurement of food intake in experiments with aphids, while the amount of honeydew produced and adult longevity (this being related to intake of carbohydrates) served as indirect estimates. In sandflies, the following techniques have been applied: (a) anthrone test has been used (Young *et al.* 1980) to detect the presence of sugar in the guts of sandflies offered different plant species in the laboratory (Schlein and Warburg, 1986; Kaddu *et al.*, 1992); (b), High Performance Liquid Chromatography (HPLC) and Gas Chromatography (GC) to identify various sugars in the guts of sandflies caught in the wild or fed on plants in the laboratory (Moore *et al.*, 1987; MacVicker *et al.*, 1990) and (c) has used the calorimetric method to

quantify the sugar content in the guts of sandflies offered and those denied sugary diets (Magnarelli and Modi, 1988).

#### **2.1.4 Insect adverse effects and plant resistance**

Insect-plant interaction has not always evolved in a mutually beneficial association. Although the formation of galls is one of the most conspicuous sequelae of insect attack on plants, insects also directly affect plants through feeding: foliage feeding, for instance, reduces photosynthesis and impairs the growth of the whole plant (Thompson, 1984).

Plants have evolved a wide array of responses and means of defending themselves against insects; the most common are physical, chemical or biological (Smith, 1989; Paxton, 1991). Different workers have proposed similar definitions on "insect-plant resistance": (a) " Plants that are inherently less severely damaged or less infested by a phytophagous pest than other plants under comparable environments in the field are termed resistant " (Maxwell, 1977); (b) " Plant resistance to insects is composed of genetically inherited qualities that result in a plant of one cultivar or species being less damaged than is a susceptible plant, which lacks these qualities " (Smith, 1989).

The latter worker has provided a well documented review on the mechanisms and effects of that phenomenon. The most common effects of plant resistance to insects are expressed as (i) antibiosis in which the biology of the pest is adversely affected, (ii) heterosis in which the plant



acts as a poor host, forcing the insect to select an alternative host, and (b) tolerance in which the plant has an inherited ability to withstand or recover from insect damage. Antibiosis is the result of a chemical defence involving allelochemicals which act as toxins (alkaloids, ketones, organic acids, etc.) or growth inhibitors (e.g. terpenoids like gossypol). Others affect insect metabolism; hydrolytic esterase activity of the soybean looper was reduced in insects fed on diets containing leaf extracts of resistant cultivars unlike those given the extracts from susceptible soybean cultivars. But chronic insect growth inhibition may result from the presence of inhibitors and from the absence or reduction in level of plant nutrients. Heterosis may be caused by chemical and mechanical defence. Repellency and deterency are among the most important mechanisms of chemical defence; they lead to heterosis. Trichomes, surface waxes, tissue thickness are physical and morphological barriers which frequently induce heterosis (Smith, 1989). Paxton (1991) has divided plant defences into two categories as outlined below. The first category which is termed preformed defence includes (a) morphological or structural defence (e.g. cuticle, lignification of cell walls, hairy and glandular trichomes) that creates a physical barrier impairing feeding and/or oviposition, and (b) various compounds referred to as allomonies, that serve to deter feeding and/or oviposition or are otherwise toxic to insects especially in critical plant parts such as flowers (Hedin *et al.*, 1991) and immature seeds (e.g. hydrojuglone glycoside in young growing parts and seed pericarp of the walnut tree). The second category comprises inducible defences; the proteinase inhibitor inducing factor (PIIF)

and the phytoalexin have been the subject of much attention. The former (primarily a carbohydrate) elicits the accumulation of proteinase inhibitors in wounded tomato leaves thus interfering with protein digestion by insects. The latter which is chemically characterised as including isoflavanoid-derived pterocarpan compounds characteristic of Leguminosae, phenanthrene compound characteristic of Orchidaceae, sesquiterpenoids compounds characteristic of Solanaceae, acetylenic compounds characteristic of Compositae etc., behaves as an induced antibiotic. These are synthesised and accumulated in plants after exposure to elicitors of abiotic or biotic origin (chilling injury, UV irradiation, cupric ions, terpenoids, tannins, polymers from microbial cell walls such as polysaccharides, pesticides, and many of those bioregulators, natural or synthetic, that increase plant resistance to pests. As in other allelochemicals, phytoalexins may exhibit different effects on different insect species: glyceollin, a phytoalexin elicited in soybeans by UV irradiations deterred feeding in the Mexican bean beetle *Epilachna varivestris* but not in the soybean looper, *Pseudoplusia includens* (Paxton, 1991).

However, within an insect species, some populations possess an inherent capability to overcome plant resistance and may transform the original allomone's role to that of a kairomone (Paxton, 1991; Hedin *et al.*, 1991). Such new populations which develop as a result of the exposure of parent populations to resistant plants are termed biotypes (Smith, 1989).

### 2.1.5 Insect- plant interaction as a potential for pest control

Different aspects of plant resistance to insects have been tested for their potential to control insects pests: (a) insects may be kept away from the host plant by various repellents (Hedin *et al.*, 1991; Lee *et al.*, 1991;); (b) insects may fail to feed and/or oviposit (through physical impairment or chemical deterrence) once in close contact with the host plant (1991; Smith, 1989; Paxton, 1991, Lee *et al.*, 1991; Tingey, 1991). The latter author reports an interesting experiment- with potential pest management application. The glandular trichomes of the wild Bolivian potato *Solanum berthaultii* enabled the plant to exhibit significant resistance against several potato beetles including *Leptinotarsa decemlineata*: responses to the encounter with the foliage of the host included avoidance, restlessness, reduced feeding, delayed development, reduced adult weight and reproductive performance, increased mortality and diminished longevity. Natural substances from plants and their synthetic analogues have proved efficient alternatives in controlling insect pests: the family of pyrethroids is a prominent example of synthetic pesticides whose structure was based on a natural product (Elliot, 1978). The gossypol from the cotton seed (*Gossypium hirsutum*) (Ishaaya, 1986) and azadirachtin and other meliacins from seed and kernel of the neem tree (*Azadirachta indica*) and the chinaberry (*Melia azedarach*) (Lee *et al.*, 1991) are good candidates as potential natural insecticides. The interference in insect growth and development by bioregulator substances such as azadirachtin and other meliacins (Rembold *et al.*, 1984; Schmutterer and Zebitz, 1984;

Schmutterer, 1987; Smith, 1989; Lee *et al.*, 1991) is a promising component in integrated pest management. Two among other advanced methods most likely to make a significant impact are: (a) the transfer of resistance factors from a plant to another through inter-hybridisation as illustrated by the experiments on various species of *Petunia* sp. attacked by some lepidopterous species (Elliger and Waiss, 1991), and (b) the elicitation of phytoalexins which act as antibiotics and anti-feedants (Paxton, 1991).

## **2.2 Carbohydrates in insects**

### **2.2.1 Importance of carbohydrates in insect life processes**

As a universal role, carbohydrates represent the form in which energy is most accessible to an animal (Macfarlane, 1985). They also play key roles in various functions of insect life processes; they constitute together with proteins and lipids the principal classes of organic compounds that are found in insects and other organisms. They are involved in all levels of the structure and functions of insect tissues (nucleus, cytoplasm, membrane, extracellular hemolymph, supporting tissues, etc.). These have sugars involved in their composition as well as in their organisation and metabolism (Chippendale, 1978).

In insect nutrition, the focus has been on classifying sugars according to their ability to enhance feeding (attractant, arrestant, phagostimulant), support optimum development, survival reproduction and longevity (Kogan, 1986; Ishaaya, 1986). Generally, glucose, fructose,

sucrose and maltose are nutritionally adequate sugars and stimulate feeding (Chippendale, 1978; Kogan, 1986) whereas cellobiose, lactose, and most of the pentoses fail to support growth (Kogan, 1986). Among the di- and trisaccharides, sucrose, maltose, raffinose, and melezitose significantly induce the activity of digestive enzymes (amylase, invertase and protease) of the larvae of *Spodoptera littoralis*. These findings are consistent with the observations reported by Lewis and van Emden (1986) that some carbohydrates do stimulate insect digestive enzymes which induce feeding. It was also shown that in general, the effects of various sugars on the digestive enzymes of *S. littoralis* larvae are correlated with larval growth and food intake. Those insects that feed as adults, commonly consume large quantities of sugars, to complement nutrient reserves carried-over from the larval stage in order to meet energy demands for flight, reproduction, and longevity (Lewis and van Emden, 1986). Examples include female Diptera, such as *Phormyia regina*, *Sarcophaga bullatta* and *Musca domestica* which must consume carbohydrates and proteins before they are able to lay viable eggs and also, fecundity and longevity of several grain feeding Coleoptera (e.g., the grain weevil *Sitophilus sp.*) (Chippendale, 1978). Longevity of adult aphids appeared to be related to carbohydrate intake (Lewis and Emden, 1986).

Besides a dietary requirement for sugars and starches, insects also need a dietary source of conjugated and derived carbohydrates in the form of vitamins and related compounds. For instance, it was found that the ascorbic acid (vitamin C), a gamma-lactone of a hexonic acid is required

for maintaining normal growth , moulting and fertility of some plant-feeding insects, including *Bombyx mori*, *Diatrea grandiosella*, *Myzus persicae*, etc. (Chippendale, 1978). Many secondary plant substances occur naturally as glycosides, which regulate insect feeding activity and therefore control host plant selection.

Another important role of carbohydrates is detoxification, the transformation of compounds into less toxic metabolites and the formation of glycosides (Chippendale, 1978).

Carbohydrates were also tried as potential control agents; *A. aegypti* was killed with poisoned sugar-baits (Lewis and Domoney, 1966) suggesting that sugar-baits should be used around breeding places of target insects.

### **2.2.2. Potential natural sources of carbohydrates for insects in nature**

There are four main potential sources (phloem sap, nectar, honeydew and pollen) of carbohydrates for phytophagous insects. The direct procurement of plant nutrients including carbohydrates was illustrated, among others, by a series of experiments on "aphid feeding and nutrition" as reported by Auclair (1963), and summarised below. The insect stylet reaches the feeding sites (mostly phloem tissues, but some species reach the xylem and others feed on woody stems) by entering epidermis inter- or intracellularly (or both) or sometimes through the stomata. These types of

penetration vary among and within species. During penetration, mechanical and chemical stimuli obviously have to be perceived for the selection of feeding sites. Varying mechanical resistance to penetration might be felt by nerves at the basis of the stylets, and possibly within them (if nerves occur within the mandibular stylets). Whereas, liquids (chemical stimuli) entering the food canal might be tested and appraised by the nerves cells around the mouth cavity (epipharynx), with the possibility of the stylets appraising some of the properties of the diet. Biochemical analysis of stylet sap revealed the presence of carbohydrates and nitrogen compounds (essentially amino acids and amides, but with no appreciable amount of proteins and peptides). Sucrose (5 to 15% in willows; 1 to 10% in 4 test herbaceous plants) was the most important among the carbohydrate constituents. However, along with sucrose, other simple sugars such as fructose, glucose and glucose-1-phosphate have also been reported from 27 host plants producing honeydew.

Hagen *et al.* (1984) reported an analysis indicating the total carbohydrate content of different parts of the plant: leaves (3.5 to 10%), fruit (4-20%) and nut (11-20%). Nectar, a plant secretion derived from the phloem sap, is more accessible as a source of sugar than the original plant sap. Its secretion is a complex physiological process taking place in special glands, the nectaries (Kevan and Baker, 1984); these glands may be housed by flowers or located extraflorally (Hagen *et al.*, 1984). The major sugars of nectar are glucose, fructose and sucrose, occurring in different proportions in different families and according to whether nectaries are protected or not

(Hagen *et al.*, 1984; Kevan and Baker, 1984).

Pollens constitute another source of carbohydrates found in plant flowers with up to 14 different sugars identified in certain flowers including common sugars, starch, etc., (Kevan and Baker, 1984).

The most widely accepted as source of sugars is the honeydew. Indeed, the impact of the honeydew on humans started with the "celestial manna" of people of Israel (Brown, 1975) and has been perpetuated essentially by apiarists (Auclair, 1963). The latter worker used the term honeydew for the liquid droplet excretion from the alimentary tract, or released through the anus by aphids, coccids and many other plant-sucking insects. Chemical analysis of honeydew revealed the presence of such simple sugars as glucose, fructose and sucrose as the main carbohydrate constituents accompanied by a few trisaccharide such as melezitose and others of glucosucrose (fructomaltose) series (Auclair, 1963; Hagen *et al.*, 1984; Macfarlane, 1985). Also found in different proportions depending on homopteran and host plant species are ribitol, d-mannitol, raffinose, stachyose, maltose and trehalose (Brown, 1975; Hagen *et al.*, 1984). Using a refractometer calibrated against sucrose for chemical analysis of honeydew from the beech scale, *Ultracoelostoma assimile* infesting the beech species *Nothofagus fusca* and *N. solandri* var. *solandri*, Grant and Beggs (1989) found the following carbohydrates and their respective proportions: fructose ( $42 \pm 5\%$ ), sucrose ( $23 \pm 8\%$ ), glucose ( $1 \pm 0.4\%$ ) and non-reducing oligosaccharides composed of glucose and fructose residues ( $33 \pm 6\%$ ).



The total carbohydrate content varied 5-64 g/100 g while protein was less than 50 mg/g. However, the quality (size of drops and concentration) and the quantity of the honeydew showed a seasonal variation, the number of anal tubes and drops peaked in winter and spring, declined in late summer and in autumn (Moller and Tilley, 1989).

On the other hand, glucogen and trehalose, stored as carbohydrate reserves in most insects are readily mobilised whenever they are needed; but in case of dramatic shortage the insect will resort to converting non-carbohydrates into glucose through a process referred to as gluconeogenesis (Chippendale, 1978).

### **2.2.3 Carbohydrates and phytophagy in sandflies**

The diet of blood-sucking Nematocera is made up of sugar and blood. Blood meals which provide proteins for oogenesis are taken infrequently during the adult's life span, while carbohydrates are consumed daily (Schlein, 1986). For a long time, more attention was focused on blood-sucking than on sugar-feeding in hematophagous Nematocera until Downes (1958) reported that males and females of many species of this group of insects feed on nectar. Using thin-layer-chromatography technique, Lewis and Domoney (1966) identified glucose, melezitose, maltose, fructose, sucrose and raffinose from the crops of blackflies from Ghana (Sudan savanna), and glucose, sucrose and fructose from the crops of sandflies caught from a forest area in British Honduras. The authors noted that the sugars identified in the crops of investigated insects were also commonly

found in nectar. Since then there was more and more evidence from field and laboratory observations to confirm the assumption that Nematoceras obtain sugar from nectar, honeydew, plant juices, or ripe fruit, a variety of sweet substances such as raisins, fresh fruit, and various solutions of commercially available syrups and honey (Chaniotis, 1974). The latter author made an interesting contribution to that subject through his study on sugar-feeding behaviour of *Lutzomyia trapidoi* under experimental conditions. He investigated some important factors likely to influence the sandfly feeding performance on sugar including the type of sugar, concentration, pH, and color. Test sugars (sucrose, fructose, maltose, raffinose, D-glucose, D-arabinose, xylose, L-arabinose, galactose, mannose, and L-glucose) were given to *Lu. trapidoi* in the laboratory. The order of acceptance among the 5 most preferred sugars was sucrose (93.4%), fructose (90.4%), maltose (80.1%), raffinose (75.9%), and D-glucose (dextrose) (66.4%). The preferred sugars included 2 monosaccharides (fructose, D-glucose(dextrose)), 2 disaccharides (sucrose, maltose) and 1 trisaccharide (raffinose), an aldose (dextrose), and a ketohexose (fructose). Among the monosaccharides, the highest feeding response was observed with the hexoses, fructose(90.4%) and dextrose(66.4%), the lowest with galactose (9.7%) and mannose (8.9%), while 2 pentoses, arabinose and xylose showed a fair performance of (14.2%) and (17.0%), respectively. L-glucose was the only sugar totally rejected (0%) by the flies. Compared with the tendency of sandflies to insert their mouthparts into water, the absolute rejection of L-glucose would suggest a possible toxicity of this compound. The author remarked that the

5 most accepted sugars are among the constituents of nectar, suggesting that the later might be among the principal natural sources of carbohydrates for hematophagous flies. Also, fructose and dextrose, which are abundant in a wide variety of fruits are important potential natural energy sources for insects. Thus, the sugar-feeding behaviour of sandflies under experimental conditions seems to reflect their natural propensity to feed on nectar, sweet plant exudates and ripe fruits. The results of Chaniotis' experiments supported those of Lewis and Domoney (1966) who earlier identified by chromatography, fructose, glucose, maltose, sucrose and raffinose in the diverticulum of wild-caught sandflies, (precisely the same sugars imbibed by *Lu. trapidoi* in the laboratory). In the same experiment the search for an optimum concentration, using solutions of 10 - 100% did not show any significant difference among the various concentrations. Apparently, viscosity and osmotic pressure do not have a vital role in sugar-feeding in sandflies. As for the hydrogen-ion concentration (pH), it was found that in general the sugar solution with neutral pH (7.1) gave a slightly better overall feeding and satiation rate over acid and alkaline solutions. However, the feeding performance of the test flies was not significantly affected within the range of 4.1 pH (acid) and 8.4 pH (alkaline). Tests for colour effect on sugar acceptance by sandflies did not reveal any significant difference among various hues within the insect resolution range {(300 nm (ultraviolet) - 700 nm (infrared))}. Thus, Chaniotis (1974) suggests that the earlier findings show that certain flies control ingestion of carbohydrates, solely through the system of chemoreceptors located on the tarsi, labellae,

labrum and cibarium.

Van Handel (1972) devised a simpler method which enabled him to detect nectar sugars in mosquitoes; the principle of the method stems from the reaction between acidified cold anthrone and fructose, giving a green or blue colour within one hour reaction. Crushed insects were dipped into anthrone solution and kept at room temperature and the results of the reaction recorded after 60 min. If the indicated colour does not appear within the determined period, the reaction was considered negative. Indeed, after 12-24 hours at room temperature or at elevated temperatures, not only fructose but all other carbohydrates including glucogen, starch and even paper will react with the reagent; fructose and fructose-yielding sugars are the only carbohydrates which react quickly with cold acidified anthrone (Young *et al.*, 1980). The method was successfully applied to detect the presence of sugar in *P. ariasi*, vector of *L. infantum* in Southern France. The highest proportions (90 and 91%) were recorded when tests were made within an hour of collection, suggesting that flies caught with small quantities of sugar reserves, probably exhausted these during the period between collection and testing. With flies maintained on water as control, some, probably those with large amounts of sugar reserves, reacted positively for up to 3 days after collection.

Endris *et al.*, (1984) conducted a laboratory study to determine the rate, age, frequency and digestion time of each meal in adults of *Lu. anthropora* given a natural sugar (honey) at 20 and 28°C. Of the flies offered honey solutions at 28°C, 93.2% fed within 24 hr (average starting age

=  $1.3 \pm 0.8$  days) after eclosion. Of 23 flies held at 28°C until death, 100% (23) fed 1x; 30.4% (7) fed 2x; 30.4% (7) fed 3x; 30.4% (7) fed 4x; and 4% (1) fed 5x. The number of sugar fed adults maintained at 20°C declined rapidly owing to the poor survival (average age for starting feeding =  $1.9 \pm 1.0$  days). Digestion of the 1st and 2nd meals required more time in flies held at 20° C ( $2.2 \pm 1.2$  and  $1.8 \pm 0.8$ , respectively) than in those maintained at 28°C ( $1.4 \pm 1.1$  and  $1.3 \pm 0.5$  days, respectively).

The experiment on phytophagy of *P. papatasi* by Schlein and Warburg (1986) was an important step toward the investigation on the source of natural sugars for sandflies. The following plant species, *Capparis spinosa* (Capparaceae); *Sinapis arvensis* (Cruciferae); *Malva nicaensis* (Malvaceae); *Solanum luteum* (Solanaceae), *Hedera helix* (Araliaceae); *Ficus carica* (Moraceae); *Crataegus aronia* (Rosaceae); *Cucumis sativus* and *Ecbalium elaterium* (Cucurbitaceae); *Smilax aspera* (Liliaceae); *Rosmarinus officinalis* (Labiatae); *Portulaca oleracea* (Portulacaceae); *Inula viscosa* (Compositae); *Atriplex halinus*, *Anabasis articulata* and *Saeda asphaltica* (Chenopodiaceae), *Spartium junceum* Papilionaceae) and *Nerium oleander* (Apocynaceae) were given to *P. papatasi* in cages (small cage for feeding behaviour observation and large cage for quantitative investigations). The results show that some plants were avoided as if they had a repellent effect; others were indifferently approached and a few elicited a real excitement, probing and feeding; males and females fed on plants in similar numbers. Most attractive among the 19 plants were *C. spinosa* (75.6%), *S. luteum* (52.1%) and *M. nicaensis* (49%). Flies readily fed on *S. junceum* (68.8%)

and *N. oleander* (54.7%) which were infested by homopterans (aphids and coccids); but when uninfested, both plants showed a feeding rate of only 2 %. They were observed feeding on stems, leaves, flowers, and fruits of plants either by piercing the tissue or feeding from the surface according to the feeding modes as described by Schlein and Warburg (1985) and summarised below. Males and females that fed by piercing, embedded their fascicle to various depths in the plant tissue with the middle segment of the palp in contact with the surface, as in typical blood-feeding mode. Surface feeding was in the sugar-feeding mode without penetration and with elevated palps. Food in the midgut indicated by the anthrone test or by the distended midgut (Schlein, 1986) in dissected flies, was observed in numerous individuals of the groups that fed from stems and leaves in the blood-feeding mode, while other meals (honeydew, artificial sugar...) were observed in the crops following the sugar-feeding mode. Intensive feeding following the introduction of plants was observed at different hours of the night. The quantitative experiments showed that a larger proportion of flies fed at night either under artificial light or in the dark.

The field observation by Ashford (1974) on sandflies feeding on various plant species in Ethiopia would have been a paramount evidence on source of natural sugar but unfortunately it was not accompanied by an appropriate test to detect the presence of sugar in the guts of the fed flies. Thus, further to the laboratory experiment on selective phytophagy (Schlein and Warburg, 1986), Schlein and Yuval (1987) performed a field test on the attraction of *P. papatasi* to various plant species. Branches of the plants

*Solanum nigrum* (Solanaceae), *C. spinosa* and *C. spinosa* var. *arvensis* (Capparaceae), *Ricinus communis* (Euphorbiaceae), *Chenopodium ambrosioides*, *Kochia indica*, *Atriplex halimus*, *Saada aegyptica*, and *Salsola vermiculata* (Chenopodiaceae), *Tamarix nilotica* (Tamaricaceae), *Prosopis farcta* (Mimosaceae) and *Amaranthus retroflexus* (Amaranthaceae) were put into different 100-ml Erlenmeyer flasks, each of which was placed close to a CDC miniature traps operating overnight without bulb. All experiments included a baited (plant) and a control trap (wet/dry filter paper). Of the 12 test plants, 8 attracted *P. papatasi* significantly more than controls. Results of field trials show that *P. papatasi* is attracted to specific plants that are potential source of sugar, but it was also found on the some plants which did not elicit feeding response in the laboratory. In laboratory tests, five plants were among the most attractive in the field (*P. farcta*, *C. spinosa*, *R. communis*, *S. nigrum*, and *K. indica*). They were fed upon by 43 - 86% of the flies, while three others (*A. halimus*, *T. nilotica* and *C. ambrosioides*) did not induce feeding. It was noteworthy that the attractive but inedible *A. halimus* is one of the dominant plant in the habitat of *P. papatasi* in the Jordan Valley and burrows of sand rat *Psammomys obesus* in which sandflies breed and rest. Therefore, sugar feeding is not the only reason for attraction to plants; other factors such as the search for shelter or breeding sites may also be of interest.

Similar to the study by Schlein and Warburg (1986) on *P. papatasi* from the Jordan Valley, an experiment on sandfly phytophagy was also undertaken by Killick- Kendrick and Killick-Kendrick (1987) on *P. ariasi*

from Southern France. Different plant species, with and without contamination from aphids producing honeydew, were offered to *P. ariasi* in the laboratory. Aphid species of the genera *Lachnus* and *Theilaxes* were the most important, especially on oak tree (*Quercus*). Some plants were infested with aphids other than *Lachnus* and *Theilaxes*: French bean (*Phaseolus* sp.) with unidentified aphids, hawthorn (*Crataegus*) with *A. citricola*, and *Calendula* with *Urolocon* sp. Among the uninfested plants, there were chestnut (*Castanea*), broom (*Genista*), etc. The results of anthrone tests showed that plants infested with aphids were preferred (18 - 75%) by test flies; but when infested and washed before the test they were not preferred except for one plant (*Genista* sp) which was fed upon by 81.8% flies. Flies fed on plants (e.g. *Phaseolus*) infested with aphids other than *Lachnus* and *Theilaxes*, whereas they did not accept honeydews from *A. citricola* and *Urolocon* sp. Based on these results, the authors concluded that honeydews of aphids and coccids were more probable sources of sugar for sandflies. However, further observations are necessary to demonstrate that *P. ariasi* never pierces plants for sugars.

The results of studies on phytophagy in some Kenyan sandflies by Kaddu *et al.*( 1992), showed that *S. ingrami* was able to feed on various plant species but at a highly variable feeding rate.

In an attempt to identify the constituents of honeydew sugars in *P. ariasi* fed on aphid-infested plants, Moore *et al.*(1987) used High Performance Liquid Chromatography (HPLC) and Gas Chromatography (GC) for analyses. Flies caught from infested plants and from a house were



tested either directly after capture, or after 4-6 day starvation, or after starvation and exposure to aphid-infested oak (*Quercus ilex*). The chromatogram (HPLC) of flies starved for 4-6 days showed no significant amount of sugar; that of flies placed on *Lachnus*-infested oak peaks in the regions of trisaccharides, disaccharides, glucose and fructose. The chromatogram with GC revealed the presence of melezitose, turanose, glucose and fructose. Turanose is a common component of a series of oligosaccharides found in aphid, coccid and psyllid honeydews. Since melezitose is absent from oak sap, but is synthesised by aphids feeding on the trees, the results of this experiment increased the probability of sandfly/aphid interaction, first suggested by Killick-Kendrick (1979) and later confirmed by laboratory experiments (Killick-Kendrick and Killick-Kendrick, 1987).

HPLC was also used by MacVicker *et al.* (1990) to identify honeydew sugars in wild-caught Italian phlebotomine sandflies, *P. perfiliewi perfiliewi* *P. perniciosus*. The study was to ascertain whether species of *Phlebotomus* which are known to be the vectors of *L. infantum* take sugar meals in the wild; if so, using melezitose as a marker, confirm whether honeydew is the source. Analysis of carbohydrates in aqueous fly extracts indicated the presence of fructose, glucose, sucrose, maltose, melezitose in each of them. The authors observed that in the fructose test with cold anthrone, it is not possible to ascertain the exact source of the sugars, and recommended further investigations with the HPLC; it is advantageous, especially because of the precision in identifying di- and trisaccharides.

Sugar feeding and plant attraction could have practical applications, especially in sandfly behaviour and control studies as demonstrated by Schlein (1987) in the following summary. The first trial was done with *P. papatasi* in Jordan Valley, Israel. Sucrose solution used as bait was coloured with a dye (Food Blue No.1 or No.2; Stern, Natanya, Israel) and sprayed on the outer lower margins of the bush surrounding the burrow of the sand rat *Psammomys obesus* (animal reservoir of leishmaniasis). The vegetation of the bush was dominated by *Atriplex halimus* and *Salsola vermiculata*; both plants were shown to attract *P. papatasi*, and *P. obesus* appears to have its burrows between the roots of *A. halimus*. The assessment was done using miniature CDC traps without bulb. A total of 3881 males and females *P. papatasi* were caught. The proportions of blue dye-marked flies (both sexes) were as follows: 25.9% during the first night following the spraying; 50% on the third night and 32.9% on the sixth night (by that time the labelling of the flies and the blue colour on the plants were less intensive). This method appears to be more efficient than the usual method of mark-release-recapture. Bait marking reached 50%, and was able to label flies for 6 nights after a single application. The author pointed out that the use of different dyes would permit behavioural studies, such as the assessment of dispersal from more than one location and evaluation of the attractiveness of different plants and of attractants mixed into the baits. Another trial of the bait-marking method on sandfly behavioural study was conducted in the focus of leishmaniasis in Baringo district, Kenya (Schlein *et al.*, 1990). The site was a deserted animal burrow surrounded by a belt of

vegetation, 10 - 40 m wide. The bait was a 20% sucrose solution coloured with Food Blue No.1 (Indigotine C.1. Stern, Natanya, Israel). The bait solution was sprayed on the vegetation using 7-l hand sprayers (Killaspray, Model 4055, Hozelock-ASL, Birmingham, England). Traps (Sticky traps or CDC light traps without bulb) were placed at 10, 50, 100, 150, and 200 m distance in 4 directions from the burrow. The results showed that the catches at different distances decreased in a linear proportion to the distance from the burrow. The total number of flies caught at different distances were as follows: 99 at 10 m (8 traps), 54 at 50 m (32 traps), 37 at 100 m (32 traps), 26 at 150 m (40 traps) and 31 at 200 m (48 traps). The sandflies species identified were essentially of the genus *Sergentomyia* (*S. clydei*, *S. schwetzi*, *S. antennatus*, *S. squamipleuris*, *S. ingrami* and *S. bedfordi*), with only 2 specimens of the genus *Phlebotomus* (1 *P. dubosqi* and 1 *P. martini*). The study showed that sandflies could disperse beyond 200 m (and even over) from such burrows known to be their breeding and resting sites in the region (Mutinga and Kamau, 1986).

#### **2.2.4 Carbohydrates and plant diets in sandfly biology**

The assessment of various carbohydrates as suitable energy source for hematophagous flies has been universally based on the criterion of adult longevity. In that context, Chaniotis (1974) evaluated the effect of different concentrations of sucrose (10%, 30% and saturation) on the survival of the laboratory-reared, *Lu. trapidoi*. The average survival of flies maintained on the respective concentrations of sucrose was 20 days on

10%, 19 days on 30 % and 18 days on saturation. A 100% mortality of the test flies was recorded after 35, 33, and 35 days when they were maintained on 10%, 30% and saturated sucrose solutions, respectively. These differences were not significant.

Endris *et al.* (1984) investigated the effect of sugar on some biological aspects {(the percentage of the blood-feeding females, the percentage of blood-fed females non-ovipositing, fecundity, duration of pre-oviposition period, percentage of females laying fertile eggs (mating), and percentage of peritrophic sac ruptures, etc.)} of the sandfly *Lu. anthophora*. The sugar effect was assessed by comparing lots of flies offered only a blood meal from *Didelphis marsupialis* (opossum), with those given sugar after the blood meal. In all cases, the effect of the complementary sugar meal was observed: (a) more females took a second blood meal after a sugar meal (49.7% vs 40.8%), (b) more females failed to lay eggs with only a blood meal (39.6% vs 19.8%), (c) females laid more eggs when given sugar after blood meal ( $28.0 \pm 13.2$  vs  $17.6 \pm 8.4$ ), (d) females denied sugar needed shorter time to lay eggs, i.e., oogenesis period was longer in females complementing blood meal with sugar ( $6.2 \pm 1.8$  vs  $4.5 \pm 1.2$  days), (e) sugar meal enhanced mating, thus leading to better fertility (83.3% vs 65.2%) and (f) sugar meal reduced the risk of peritrophic sac rupture (4.9% vs 11.7%).

The plant, *C. spinosa*, which proved very suitable in the experiment on phytophagy of *P. papatasi* (Schlein, 1986) was tested for its effect on the longevity of the same sandfly species. It has pronounced effect, without

challenging the performance of sucrose (Killick-Kendrick, 1987).

Sugar feeding is very important in the biology of sandflies since their movements (dispersal) in the field are often in connection with the search for sugar. Yuval and Schlein (1986) carried out an investigation on the activity patterns of *P. papatasi* around *Psammomys* burrows and found that males, gravid and blood fed females were active between sunset and midnight: that activity was mainly motivated by the search for sugar. On the basis of these observations, the authors suggested that female sandflies exiting from burrows when in need for a sugar meal would be an appropriate target for control (using sugar baits containing a control agent); great success will be achieved if the target population (*Leishmania* infected females) inhabiting a limited area (near burrows) exhibits a well defined appetitive behaviour (sugar feeding).

#### **2.2.5 Carbohydrates and plant diets in *Leishmania* infectivity**

The realisation of the importance of sugars on the development of leishmanias and their transmission by sandfly vectors was impacted by the search for the vector of kala-azar in India (Adler and Theodor, 1957). Indeed, after many years of trials, successful experimental transmission of *L. donovani* to the gold hamster and to man by the bite of *P. argentipes* was achieved only when the flies were given raisins after the blood meal. One of the probable explanations of the previous failures was that parasites in the foregut (oesophagus, pharynx, cibarium) and the proboscis were in a rather

barren environment (Killick-Kendrick, 1979; Young *et al.* 1980) unable to sustain them, and could not directly benefit from the products of blood meal digestion. However, it was found later that the routine supply of sugar of the sort of sucrose or raisins to test vectors in experimental transmission could lead to unpredictable results. This observation indicated that natural sugars may provide essential substrate for leishmanias (Killick-Kendrick *et al.*, 1977) or plant diets in nature contain nutrients other than sugar, necessary for the parasites (Schlein, 1986). This point was illustrated by the differential location of *L. infantum* in the gut of laboratory infected *P. ariasi*: when the sandfly vector was maintained on raisins in the laboratory, the infection was limited to the midgut. Whereas, similarly infected flies that had been released in the wild and recaptured, had parasites in the foregut; these were therefore potential transmitters (Killick-Kendrick, 1979; Schlein, 1986, 1993). It has also been shown that growth of parasites in a sugar medium induces the transformation of *Leishmania* to the form observed in sandfly (Sacks and Perkins, 1984). Furthermore, since honeydew and plant sap also contain amino acids (Auclair, 1963) the effect of the protein in the sugar meal on the potential of *P. papatasi* to transmit *L. major* was investigated (Schlein, 1986). The latter author estimated the vector capacity by counting the number of parasites ejected into capillaries during forced feedings. The percentage of flies that ejected more than 100 parasites was significantly greater in those fed on sugar-albumin mixture than flies given a solution of either sucrose or albumin alone. It has also been shown that carbohydrates have a significant role in determining the behaviour of leishmanias in sandflies.

### 2.2.6 Potential adverse effects of carbohydrates and phytophagy on sandflies and *Leishmania*

Sugar meals might constitute a source of contamination which may become fatal for sandflies whose gut is normally clear of microorganisms; blood taken by bite is generally clean whereas sugars coming from free fluids like nectar are likely to carry bacteria and/or fungi (Schlein *et al.*, 1986). In their experiment with *P. papatasi*, they demonstrated the existence of an anti-bacterial factor which maintains the antiseptic state of sandfly gut. In addition, they related the gut sterility to the processes of obtaining meals by sandflies routes followed by different meals. Schlein and Warburg (1985) summarised the processes: carbohydrate meals taken by piercing of plant tissues are found in the midgut while sugars taken from wet cotton wool go to the crop. This system which directs the carbohydrates to two different destinations might have evolved into gut sterility. It has ensured maximum efficiency, since the quantity of anti-bacterial matter is limited. On the other hand, it has been established that the environment for *Leishmania* development in the sandfly gut includes two different nutrient media: constituents of plant sap and blood and digestive enzymes which may positively or negatively affect *Leishmania* parasites (Schlein, 1986; Borovsky and Schlein, 1987).

Sugars in particular and phytophagy products in general might be harmful to both the insects and the parasites they harbour. Indeed, high mortalities were observed in sandflies fed on unsterilised raisins in the

laboratory (Killick-Kendrick 1979) probably due to a massive contamination by bacteria and fungi (Schlein, 1988). While some food plants seem to facilitate transmission of infection, others might be harmful to the parasite or the vector. Among the obvious candidates, are the poisonous plants (some species of *Solanum* and *Ricinus*) which *P. papatasi* fed upon (Schlein, 1986). The lectins in the tissues of many plants, reacting specifically with *Leishmania* promastigotes in culture, were toxic to some of the parasites (Schlein, 1993). *L. major* promastigotes undergo selective changes in surface carbohydrates due to the agglutination by plant lectins. These changes paralleled the transformation from non-infective to infective promastigotes (Sacks and Perkins 1984). These findings led to the postulation that carbohydrate-lectin-*Leishmania* interactions govern the development and infectivity of the parasites within the vector, and that sugar feeding is integral to the system (Blackwell, 1985).



## CHAPTER 3

### MATERIALS AND METHODS

#### 3.1 Materials and experimental conditions

##### (1) The test plants.

Seven species (Plates 1-7), indigenous or introduced to Kenya, (i) *Azadirachta indica* A. Juss (Neem tree) (Meliaceae), (ii) *Melia azedarach* L. (Chinaberry) (Meliaceae), (iii) *Ocimum suave* Wild. (Labiatae), (iv) *Ocimum kenyense* Ayobangira ex Paton (Labiatae), (v) *Rumex usambarensis* Dam. (Polygonaceae), (vi) *Solanum incanum* L. (Solanaceae), and (vii) *Tagetes minuta* L.(Compositae), were chosen for the present study, because of their sympatric distribution with phlebotomine sandflies more or less associated with leishmaniasis in the Kenyan foci (e.g. Baringo District) and their confirmed or potential role in various aspects of pest control.

(a) *A. indica* and *M. azedarach* are being intensively investigated because of, among other economic interests, their strong potential in pest control (Noad and Birnie, 1990; Lee *et al.* 1991).

- (b) *O. kenyense*, another, but less documented, tropical shrub, mostly found in fallow fields has got a very strong scent which necessitated its assessment for some property likely to elicit a behavioural response in sandflies: attractancy/repellency and/or phagostimulation/feeding deterrence.
- (c) *O. suave* has interesting records of its use as a traditional repellent to stored crop pests and mosquitoes (Watt & Breyer-Brandwijk, 1962; Hassanali and Lwande, 1989; Paton, 1991).
- (d) *R. usambarensis*, popularly reputed for its sweetness and the property of thirst relief (Watt & Breyer-Brandwijk, 1962), has already been used as a source of carbohydrate in sandfly colonisation at ICIPE.
- (e) *S. incanum* and other *Solanum* species have been reported as poisonous plants (Watt and Breyer-Brandwijk 1962; Schlein, 1986); yet some species were able to attract *P. papatasi* in the Jordan Valley, Israel, resulting in a relatively high feeding rate (Schlein, 1986).
- (f) *T. minuta*, considered as one of the most troublesome weeds (Agnew, 1974; Akobundu, 1987; Aulakh *et al.*, 1987) is receiving a sustained interest, due to its potential in pest control (Green *et al.*, 1991;

Siddiqui *et al.*, 1988; Jordan *et al.*, 1988; Ijani and Mmbaga, 1988) specifically as another potential source of natural pyrethrins (Kamal & Mangla, 1987).

All the plants were identified in collaboration with the Herbarium Unit of the Botany Department, University of Nairobi, Kenya.

For convenience, the names of these test plants as well as sucrose and water will be abbreviated in tables and graphs as follows: *A. indica* (Ai), *M. azedarach* (Ma), *O. kenyense* (Ok), *O. suave* (Os), *R. usambarensis* (Ru), *S. incanum* (Si), *T. minuta* (Tm), Sucrose (Su) and Water (Wa).



Plate 1: *Azadirachta indica* A. Juss (Meliaceae).



Plate 2: *Melia azedarach* L. (Meliaceae).



Plate 3: *Ocimum kenyense* Ayobangira ex Paton  
(Labiatae).



Plate 4: *Ocimum suave* Wild. (Labiatae).



Plate 6: *Solanum incanum* L. (Solanaceae).





Plate 7: *Tagetes minuta* L. (Compositae).

**(2) The test insects.**

Two species of phlebotomine sandflies, *Phlebotomus duboscqi* Neveu-Lemaire, 1906 (Plate 8a) and *Sergentomyia ingrami* Newstead, 1912 (Plate 8a-b) of the genera, *Phlebotomus* Rondani and Berté, 1843 and *Sergentomyia* França and Parrot, 1920, respectively, were the insect materials for the whole study. They belong to the subfamily Phlebotominae Kertész, 1904, family Psychodidae Bigot, 1854, superfamily Psychodoidea Lameere, 1936, suborder Orthorrhapha, section Nematocera, order Diptera (Dolmatova and Demina, 1971; Abonnenc, 1972; Lewis, 1982; Killick-Kendrick, 1990). *P. duboscqi*, is now considered as an important vector of *L. major* which causes cutaneous leishmaniasis in tropical rural areas of the Old World (Bray, 1974). It has a transafrican expansion from the Atlantic to the Indian Ocean passing through Senegal-Nigeria-Kenya (Beach, *et al.*, 1984; Asimeng, 1985; Killick-Kendrick 1990). *S. ingrami*, which is numerically very important in the Kenyan foci of leishmaniasis was reported to harbour uncharacterised flagellates which could be of the genus *Leishmania* (Kaddu *et al.*, 1986; Mutinga 1991). The test flies of both species came from laboratory-reared colonies raised from wild strains collected from Marigat, Baringo District, Kenya.

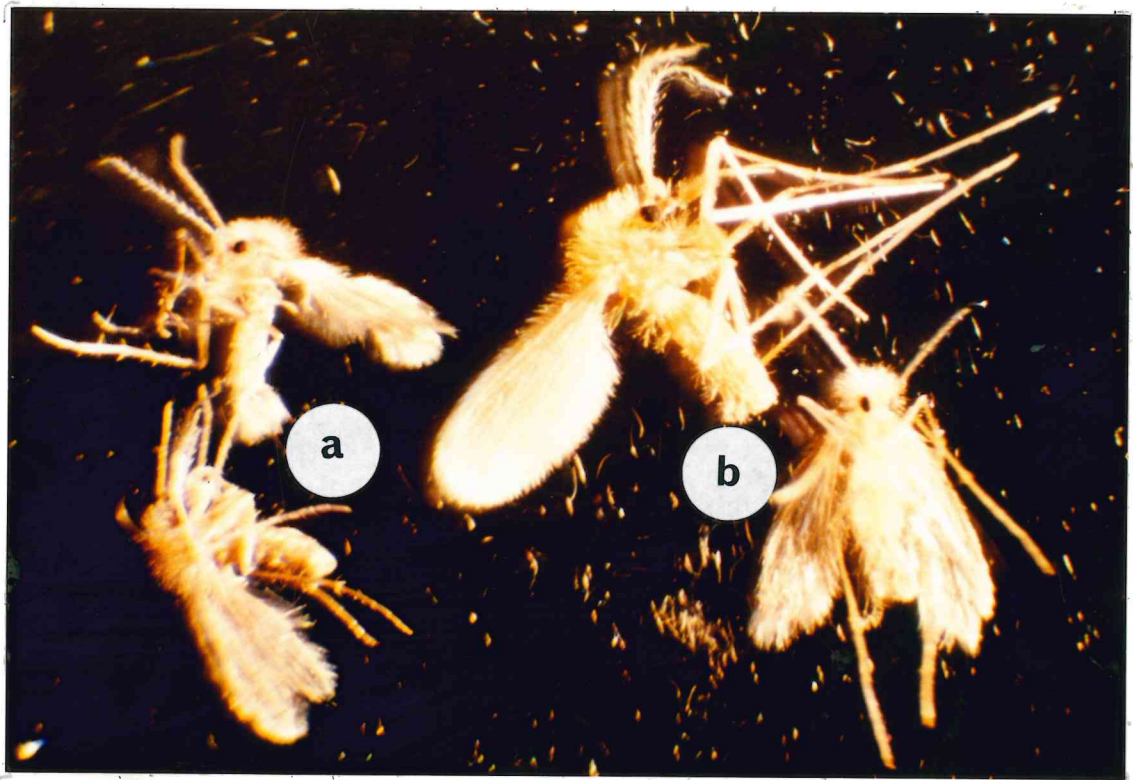

Plate 8a-b: The test insects, *Sergentomyia ingrami* Newstead 1912 (a)  
and *Phlebotomus duboscqi* Neveu-Lemaire 1906 (b).

**(3) The test parasite.**

The parasite used is the ICIPE strain 226 of *Leishmania major* Yakimoff and Schokhor, 1914, emend. Bray, Ashford and Bray, 1973 (Lainson and Shaw, 1987), as characterized by Chance (1978) on the isolates obtained from Kenyan wild animals in Kerio Valley by Heisch (1963) and confirmed on the isolates from *P. duboscqi* (Beach *et al.*, 1984). *L. major* is among the accepted species of the genus *Leishmania* Ross, 1903 (Lainson and Shaw, 1979, 1987; Killick-Kendrick, 1990) belonging to the family Trypanosomatidae Doflein, 1901, emend. Grobben, 1905; suborder Trypanosomatina Kent, 1880; order Kinetoplastida Honigberg, 1963, emend. Vickerman, 1976; class Zoomastigophora Calkins 1909; subphylum Mastigophora Deising, 1866; phylum Sarcomastigophora Honigberg and Balamuth, 1963; subkingdom Protozoa Goldfuss, 1817; the kingdom Protista Haeckel, 1866 (Lainson and Shaw, 1979; Molyneux and Ashford, 1984; Walton, 1983). Another classification based on the behaviour of *Leishmania* in the sandfly-host gut (Plate 18) but without a taxonomic status divides the parasites of this genus into three sections : (i) Hypopylaria, restricted to the hindgut and presumably transmitted after ingestion of infected insect; (ii) Peripylaria, retaining a hind gut stage in development but migrating to midgut and foregut to be transmitted by bite; (iii) Suprapylaria, restricted to midgut and foregut and transmitted by bite (Lainson and Shaw, 1979). *L. major* belongs to the last category. *L. major* is one of the known leishmanial

species causing cutaneous leishmaniasis in the Old World (Bray, 1974, 1987), particularly in Kenya where the parasite is transmitted by the sandfly *P. duboscqi* (Beach *et al.*, 1984; Kaddu, 1986; Mutinga, 1991; Killick-Kendrick, 1990). Moreover, *L. major* is a leishmanial parasite for which a murine model of infection has been well-established for experimental transmission (Titus and Ribeiro, 1990).

**(4) The experimental animals.**

**(a) Source of blood meal for oogenesis in sandfly laboratory rearing.**

*P. duboscqi* was given the hamster *Mesocricetus auratus auratus* (Rodentia: Cricetidae) (Plate 9) which has proved suitable for other species of *Phlebotomus*, while *S. ingrami* was offered a geconid lizard, (Killick-Kendrick, 1977; Mutinga *et al.*, 1986 Mutinga *et al.*, 1989).

**(b) Source of *L. major* for experimental transmission.**

BALB/c mice *Mus musculus* (Rodentia: Muridae) (Plate 10) have proven a suitable material for harbouring heavy infections of *L. major* in other trials on experimental transmission (Bray, 1987). In the present study, the starting lot was made of eight 4-week old females (average weight = 11.5 g) supplied by the ICIZE's Insect and Animal Breeding Unit (IABU). These were infected by inoculating a culture suspension of *L. major* from ICIZE cryobank into footpads, mouth/nose and tail areas, and maintained on a

diet made of special mice cubes and water (Kagoia, unpublished) in the Parasitology Laboratory of the ICIPE's Medical Vectors Research Programme (MVRP). After a two-month incubation, 5 out of 8 inoculated mice presenting signs of infection (swelling and ulcers on the inoculated areas) were screened and found positive for *Leishmania* amastigotes. The average weight of the mice which was 11.5 g on delivery, reached 18.5 g before their exposure to sandflies.



**Plate 9:** Feeding *P. duboscqi* on a hamster *Mesocricetus auratus auratus* (Rodentia: Cricetidae) as a source of blood meal for oogenesis.



Plate 10: Feeding *P. duboscqi* on a *Leishmania major* infected BALB/c mouse *Mus musculus* (Rodentia: Muridae) as a source of infective blood meal.



**(5) The Feeding cages**

The feeding cage for sugar or water originally designed by Chaniotis (1974) has been adapted with some improvement by Modi and Tesh (1983), Beach *et al.* (1983) and Mutinga *et al.* (1989). The current version (Plate 11) is a rectangular perspex box 15.0 x 15.0 x 20.2 cm, with the upper side made of a netting material for aeration but which also provides a resting surface for flies. In the center of one of the lateral sides, there is a 10 cm-diameter hole for introduction of flies; it can be closed and opened using a sleeve stuck along its circumference. The feeding cage used for plants (Plate 12) is a modified version of the Schlein's type (1986). In the new model, which retains the same dimensions as above, the upper side functions as a hinged flap, movable and which is closed tightly by rubber bands, rolled around the steadies. This device is meant to facilitate the introduction of all test plants, including the thorny ones.

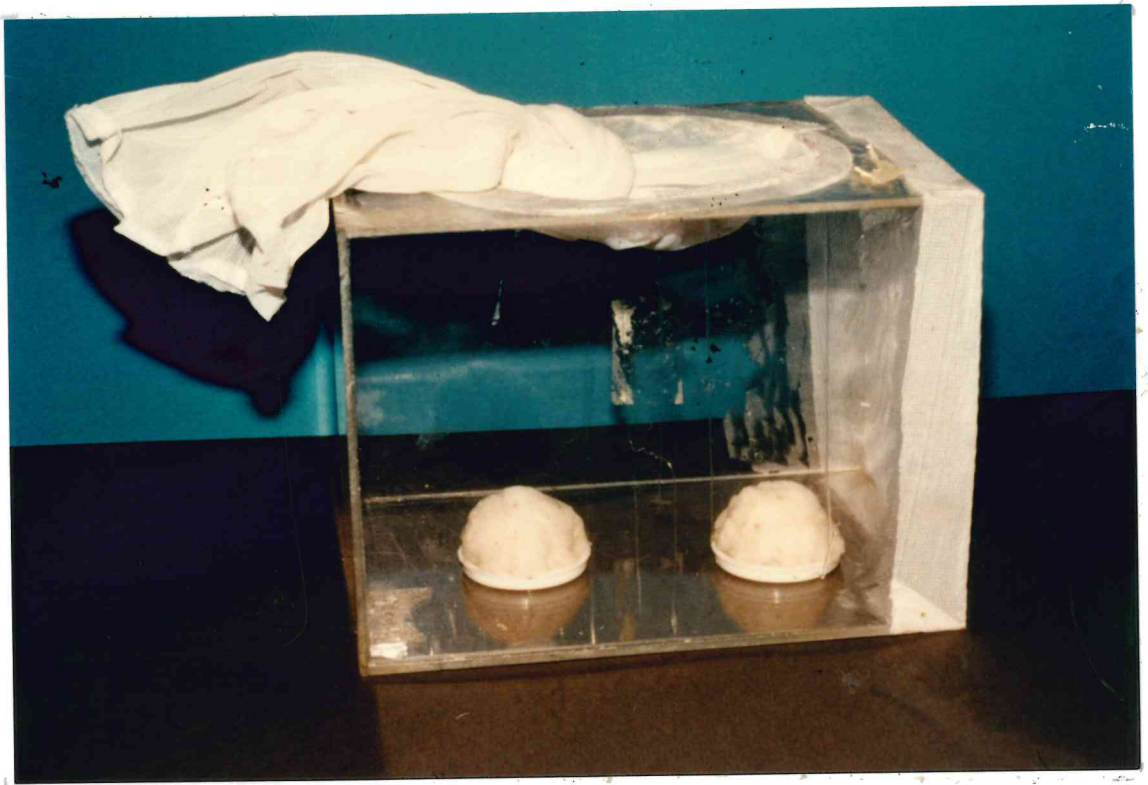

Plate 11: Feeding cage for sugar or water.



**Plate 12:** Feeding cage for plants.

**(6) Anthrone reagent and microtiter plate**

The reagent used was anthrone (BDH Chemical Ltd, Poole, England) at 1.25% concentration (w/v) in a solution of 72% (v/v) sulfuric acid. The reaction was performed in a 96-well (12 x 8) sterile microtiter plate of different makes but with the same characteristics (NUNC, made in Denmark; GREINER, made in Germany; COSTAR, made in England) (Plate 13).

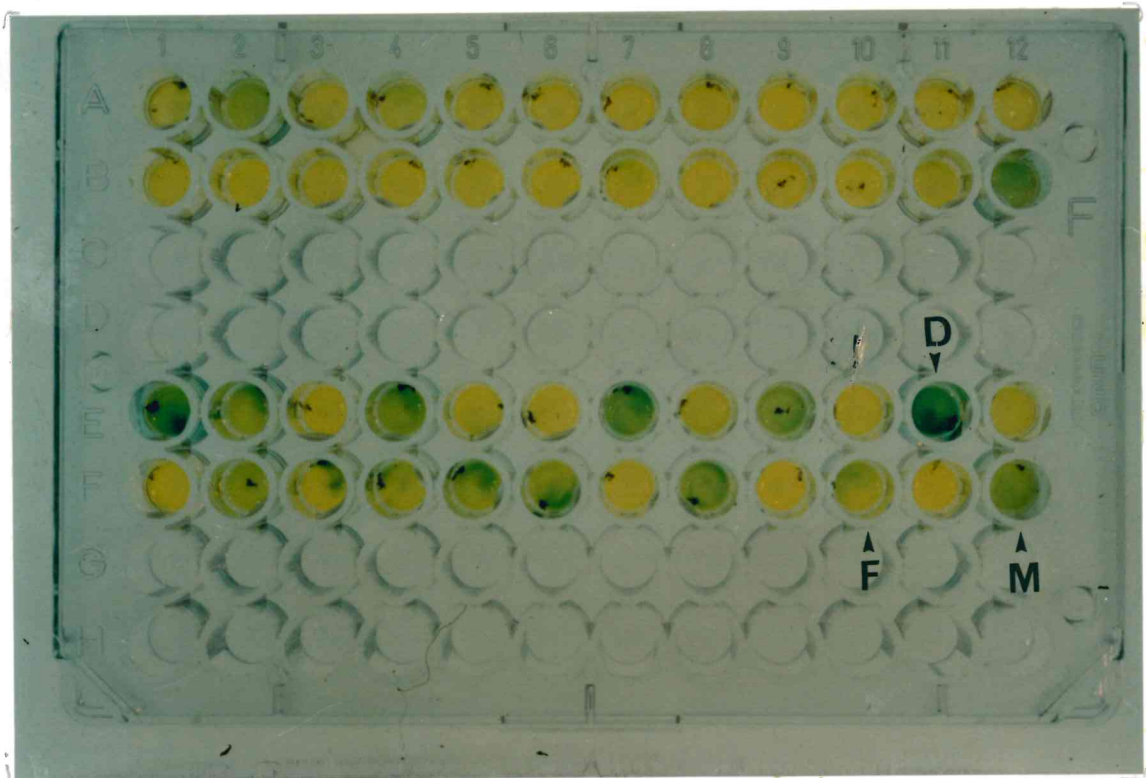

**Plate 13:** Microtiter plate with anthrone reagent (yellow colour) and different levels (D = Deep; M = Medium; F= Faint) of blue colour intensity in wells with positive reaction.

**(7) Materials and chemicals for assessment and estimation of sugar content in plant materials**

**(a) Direct water extraction for total water soluble sugars**

Plants materials were ground using the " WARING Commercial Blendor (Waring Products Division, Dynamics Division Corporation of America, New Hartford, Connecticut 06057, made in U.S.A.)". The first filtration was done with an aspiration system, comprising a Buchner funnel and a filtering flask complemented by the aspirator pump (Model 7049-05 Cole-Palmar Company, Chicago, Illinois 60648) of a rotary evaporator (Rotavapor Buchi R111, Switzerland). In the subsequent filtrations, activated charcoal [Activated carbon, Darco (R), 20-40 mesh granular, (R) American Norit Co., Inc., Aldrich Chemical Co. Ltd, Gillingham, Dorset, England)] was used to clear the blend.

**(b) Sequential extraction**

Different solvents were used in the following order of increasing polarity: petroleum ether, acetone, methanol (MERCK, West Germany) and distilled water. After a 4-day maceration, the mixture containing extraction liquid (solvent + extract) was filtered as described in (a). The water content (especially in extraction with petroleum ether) was removed with calcium sulfate. The solvents were eliminated using a rotary evaporator system as described in (a). The remaining water was removed by a freeze-drier " Virtis Gardiner, N.Y. 12525 Model No.10-030 ".

**(8) Apparatus for assessment of attractancy/repellency**

This system is a modification of the flight wind tunnels designed for flying insects (Jermy, 1976; Tingle, 1989) in an attempt to adapt it to sandflies which are small, hopping insects (Molyneux and Ashford, 1983) and to the use of natural whole plant materials instead of extracts. The apparatus (Plate 14) comprises 3 parts including: (a) a rectangular tunnel-like body with three partitions, (i) the main chamber (34.4 x 17.4 x 17.4 cm) in the middle, (ii) 2 lateral detachable chambers (18.0 x 18.0 x 16.4 cm) sliding inward respectively, over either lateral end of the main chamber, the remaining space (18.7 x 18.0 x 61.5 cm) of the lateral chambers providing room for assay materials; the external lateral side of the middle and lateral chambers can open and close by detachable gates (17.0 x 17.0 cm and 18.6 x 18.0 cm, respectively); at the center of each gate is a hole, air inlet (12 cm-diameter for the main chamber and 8 cm-diameter for the lateral chambers) covered by a netting material; (b) a detachable release chamber (6.9 x 6.5 x 6.5 cm) in the mid-central area of the front side of the main chamber; in the central junction between the main and the release chambers, two communicating holes (2.0 cm-diameter for the entrance of the main chamber and 1.3 cm-diameter for the release chamber) allow the introduction of flies from the release chamber to the main chamber; the release chamber has a second hole (1.3 cm-diameter) on the upper side through which flies are introduced using a sucking tube; (c) the suction system of the apparatus is composed of (i) an air outlet tube (0.6 cm-diameter) passing through the center of the top side of the main

chamber and attached to a double funnel (truncated pyramid with 4.5 x 4.5 cm-base and 6 cm-height) hanging inside in the centre and opening towards the air inlet gates of the main and lateral chambers, (ii) a flowmeter (Gilmont Instruments, Inc.) for measuring the air flow entering through the gates, (iii) and a suction pump connected to a water tap.



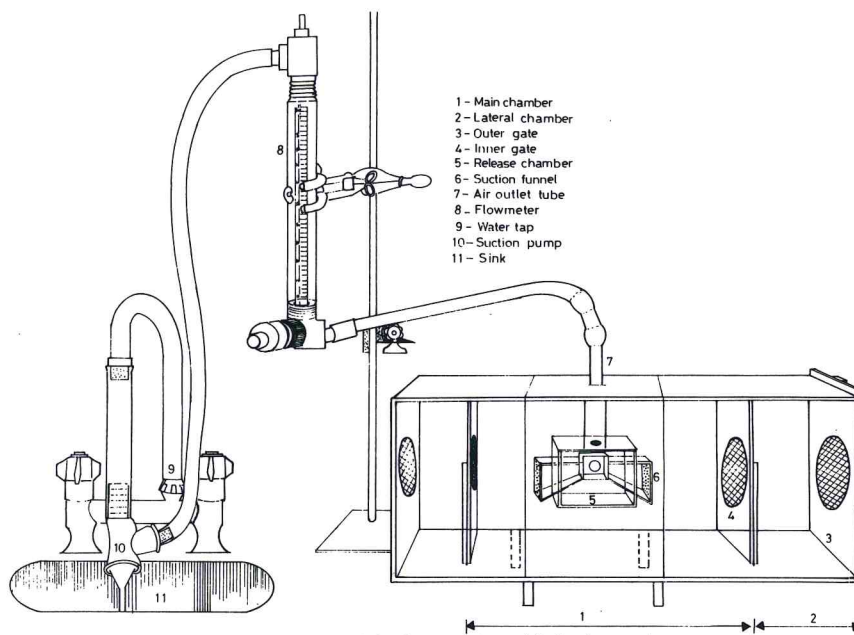

Plate 14: Diagram of the apparatus designed to carry out tests on behavioural response by Phlebotomine sandflies to olfactory stimuli from different test plants

**Plate 14:** Diagram of the apparatus designed to carry out tests on behavioural response by Phlebotomine sandflies to olfactory stimuli from different test plants.



**Plate 15:** Set-up for assessment of behavioural response by *P. duboscqi* to odours from different test plants using the apparatus described in Plate 14.

**(9) Individual oviposition vial**

The oviposition vial is an adapted model from the type designed by Kapur and Mutinga (1981). The new version (Plate 16) retains the basic characteristic of the original as far as material (plastic) and dimensions (8 cm length/2.5 cm diameter) are concerned. The actual modifications consist of: (i) a plaster of Paris plug through a 7 mm diameter hole in the center of the bottom which is in contact with the water soaked cotton wool in the moisture keeping container (described below); (ii) the provision of the lid with a central hole (7 mm diameter) to accommodate diets (plant, sugar, water) and concentric small holes for aeration.

**(10) Moisture retention system**

The system (Plate 17) consists of a rectangular perspex box (16.2 x 16.2 x 8.2 cm) with a square tube-holder perforated with 25 holes (2.6 cm diameter) for 25 oviposition vials. The tube holding rack is retained inside the container by 2 parallel stoppers fixed at 5.3 cm from the bottom; the latter is lined with a thick layer of cotton wool that is permanently imbibed with water.

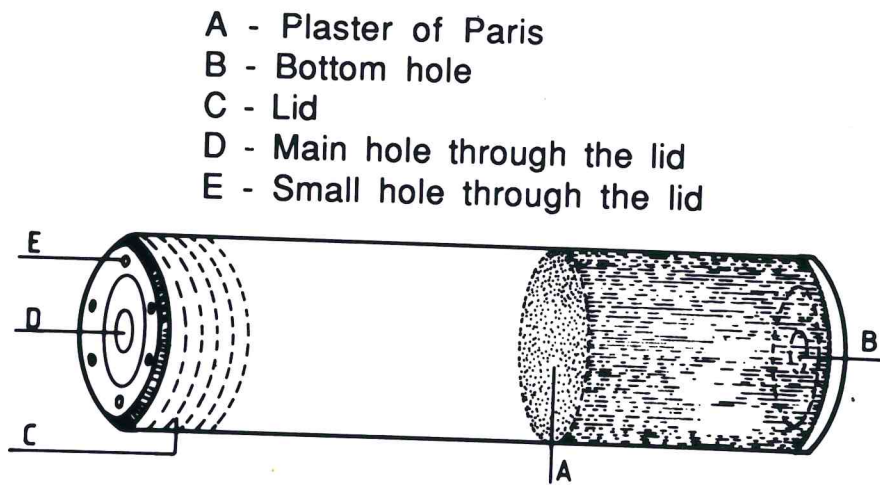
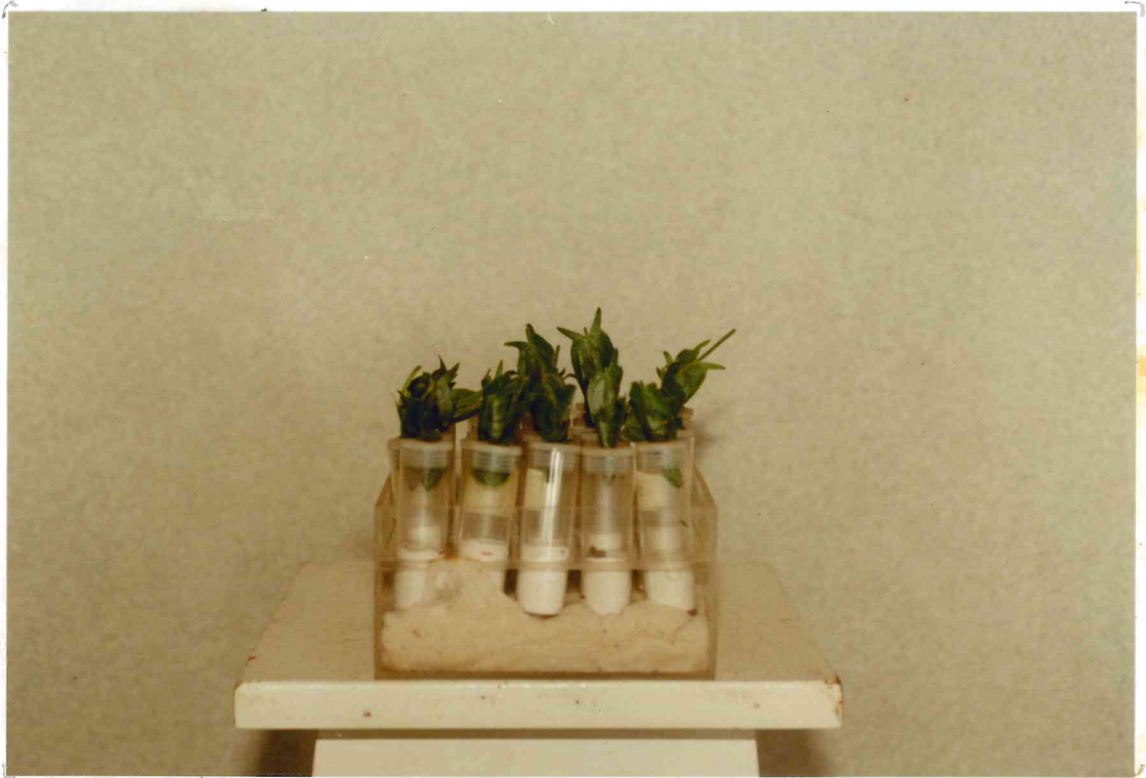

Plate 16: Individual oviposition vial designed with provision for permanent moisture retention and renewable diet supply.



**Plate 17: Set-up of humidity retention system containing individual oviposition vials with plant diet supply.**

**(11) Materials for monitoring biological events and reading chemical reactions**

A stereoscopic dissecting microscope was used for (i) checking and counting eggs, larvae, and pupae in monitoring fecundity, developmental duration and survival of the immature sandflies, and (ii) checking the result of the reaction in the anthrone test; a compound microscope served for the observation of parasites in cultures, infected sandfly and experimental animal preparations.

A quantitative estimate of sugar content in water extracts from different test plants was obtained with a BECKMAN Du-50 Spectrophotometer (Palo Alto, Calif., USA).

**(12) Materials for monitoring experimental conditions**

Experiments on sandfly feeding, rearing, and longevity and on *Leishmania* infectivity took place in an incubator (Memmert Elektronik, made in West Germany) with controlled temperature and adjusted humidity: phytophagy and other experiments on sandfly biology were conducted at  $28.5 \pm 0.3^{\circ}\text{C}$  and 60-70 Rh while the temperature for incubation of *Leishmania* was adjusted at  $27.5^{\circ}\text{C}$ .

Bioassay tests were run in a 3 x 5 m room provided with a sink and a water tap. The lighting was provided by two incandescent tubes: a proximal red tube above the bioassay apparatus and a distal white one near the door.

The assay was run in darkness, excluding a short period for recording during which the two tubes were put on, the white light giving enough illumination for counting flies while the red one maintained them under dim conditions. A water bath allowed to maintain the temperature around 25°C and the humidity at 60-70% Rh. A fan air conditioner extracted residual odours.

## **3.2 Methods**

### **3.2.1 Phytophagy and feeding performance of *S. ingrami* and *P. duboscqi* offered various plant species**

#### **3.2.1.1 Standardisation experiments**

##### **(a) Optimum anthrone concentration**

Demonstration of the actual phytophagy implies the possibility of detecting the presence of plant sap components (e.g. sugars) in the gut of sandflies, after a given exposure time to the test plant materials.

Different techniques, including thin layer chromatography (TLC) (Lewis and Domoney, 1966), gas chromatography (GC) (Moore *et al.*, 1987) and high performance liquid chromatography (HPLC) (Moore *et al.* 1987; MacVicker *et al.*, 1990), have been used for the identification and quantification of sugars in the gut of sandflies. The anthrone test is more practical and easier to handle, especially in the field (Van Handel, 1972). The sensitivity of anthrone varies according to the manufacturer; for instance, the reagent available in Nairobi and labelled "BDH Chemical Ltd Poole England" has a 1% minimum sensitivity for sucrose whereas Young *et al.*, (1980) was able to perform the test with 0.1% concentration. Thus, it was important to conduct a standardisation trial to determine the optimum concentration.

Teneral 2-4 day old laboratory-reared *S. ingrami* were put into the feeding cage and given 10% sucrose in a pad of cotton wool; the cage was



kept overnight in the incubator under the conditions defined above. After the feeding period, the flies were transferred into a vial and kept momentarily in a deep freezer (- 20°C) for immobilization during the dissection. The transfer of flies from a container to another was undertaken with a mouth aspirator (Plate 8). The dissection, consisting of the extraction of the gut was done under a dissecting microscope using entomological pins, insects lying on a slide in a drop of normal saline. The dissected material was dipped into the wells of a microtiter plate containing a cold anthrone solution; the reaction was read after 60 min. The sample unit was 24 flies, corresponding to the number of holes in 2 rows of a microtiter plate. Three different anthrone concentrations were tested: 1%, 1.25% and 1.5% (w/v). The positive reaction between anthrone and fructose gives a blue/green colour (Plate 13) with three levels of stain intensity (deep, medium, faint). The feeding rate was expressed as the percentage of the ratio of the number of positive reactions over the number of flies dissected. The stain intensity correlated with the feeding intensity will be referred to as feeding performance, expressed as the percentage of positive reactions of a given stain level over the total number of flies dissected. On the basis of the results of the tests done with different concentrations, 1.25% was chosen for the subsequent tests using the same type of anthrone.

**(b) Exposure time**

Time standardisation was done on three diets including one test plant, *R. usambarensis* and the two controls (sucrose and distilled water). The

plant samples were collected in the surroundings of ICIPE (Kasarani, Nairobi, Kenya) where the plant is found throughout the year. The test plant materials (mostly leaves or young shoots) were washed with tap water, rinsed with distilled water and left to drip before the exposure; this precaution was meant to rule out the possibility of introducing into the test any sugar from any source other than the plant sap. To avoid water loss and withering of plant materials, the lower end parts of the shoots or branches bearing leaves were plunged into bottles containing water; the mouths of the bottles were sealed with parafilm.

For each diet, teneral flies were allowed to feed for a period of 1, 2, 3, 4,...24 hours. After each feeding period, cages were removed from the incubator, flies transferred into vials which were placed in a deep freezer for immobilization, then dissection and anthrone test were run as above. The feeding rate of both sandfly species on *R. usambarensis* was checked against sucrose and water.

### **3.2.1.2 Feeding *S. ingrami* and *P. duboscqi* on different plant species**

The objective of the test was to assess whether various plant species present different degrees of suitability to these species. In addition to *R. usambarensis* already used in standardisation tests, the other species were: *A. indica*, *M. azedarach*, *O. kenyense*, *O. suave*, *S. incanum* and *T. minuta*. A total of 288 (12 replicates of 24) teneral flies were exposed to each of the

seven plant species and the two controls in appropriate different feeding cages which were kept overnight in an incubator. The effect of the age of plant materials on the feeding response was assessed by comparing the feeding rates when *P. duboscqi* was offered young and old leaves of *M. azedarach*, while in the same way the suitability of different parts of the plant *S. incanum* (leaves, flower, fruit, whole comprising the other 3 + stem) in both sandfly species *S. ingrami* and *P. duboscqi*. In the latter experiment, fruits were exposed with and without peduncle and flowers were exposed completely isolated (other terminal parts of the branch sealed with parafilm) and not completely isolated, respectively. After the feeding period, dissection and anthrone test were performed as described above. The feeding performance with reference to carbohydrates was described by the three levels D (deep), M (medium) and F (faint) according to the intensity of the blue colour of the positive reaction between anthrone reagent and fructose or any sugar with fructose moiety.

### **3.2.3 Estimation of sugar content in the test plants**

The following test was designed to estimate sugar content (by anthrone test and spectrophotometry) in water extracts from the test plant already assessed for phytophagy. Water extracts were obtained by (i) direct extraction by grinding and maceration in water of fresh plant materials and (ii) by subjecting plant materials to sequential extraction using different solvents (petroleum ether, acetone, methanol and water).

### **3.2.3.1 Water extracts from test plants**

#### **(a) Direct water extraction of fresh plant materials**

100-200 g of fresh young leaves were washed to remove any contamination by sugars of external origin. Clean materials were chopped before grinding in a blender with water. The blend was allowed to macerate for 45-60 min in cold water (total amount of grinding and rinsing water was 1000-2000 ml according to the quantity of plant material). After maceration the blend was filtered using a Buchner funnel and filtering flask, complemented by the aspirator pump of the rotary evaporator. The first filtrate was a greenish liquid which was cleared through subsequent filtrations using activated charcoal mixed by a stirrer. The clear extract (as limpid as distilled water) was subjected to anthrone test and spectrophotometry procedures. To determine an optimum volume for final test, trials were done with 2.0; 1.0; 0.5; 0.2; and 0.1 ml added to distilled water to make a total volume of 2.0 ml. The optimum volume (variable according to the plant species) was tested in 5 replicates. The calculation of the final concentration took into account the successive dilutions.

#### **(b) Water extracts from plant materials subjected to sequential extraction**

Young fresh leaves (or shoots) of the test plants were washed and left to drip until the washing water was eliminated through evaporation, then they

were chopped, weighed and introduced into an extraction bottle (2.5 l) in which they were immersed with the appropriate solvent. After 4 days of maceration, the extract was filtered and the solvent removed using the rotatory evaporator. The remaining water was removed by calcium sulfate for the extraction with petroleum ether or by freeze-drying for the other solvents, the final product being a solid extract. The following steps were used for the preparation of test solutions.

**(i) Extraction of sugars from crude extracts**

Five samples (0.117 g each) of extract from each plant were put into different test tubes and subjected to sugar extraction with 80% ethylic alcohol. Samples of crude extracts were introduced into test tubes containing 2 ml of the alcohol. They were left for 30 min in a boiling water bath, then removed and left to decant; the supernatant was transferred into another test tube, while the deposit was subjected to the same extraction. The operation was repeated 3 times in order to extract maximum sugar content. The total supernatant collected was centrifuged at 5000 rpm for 10 min; the final supernatant collected into a test tube, was kept in a boiling water bath to evaporate as much alcohol as possible until only 2 ml liquid remained (when the final volume was less than 2 ml, the required volume of 2 ml was obtained by adding distilled water).

**(ii) Preparation of solutions for anthrone test and spectrophotometry**

A subsample (0.5 ml) of the final solution (2 ml) obtained after the above extraction procedure was diluted (10 times) by adding it into a test tube containing 4.5 ml distilled water to make 5.0 ml. From each tube 0.1 ml was put into a new test tube containing 1.9 ml distilled water to make up 2.0 ml.

**3.2.3.2 Sugar standard solutions for standard curves**

Sugar concentration in test plants were referred to three standard sugars (fructose, glucose, sucrose). Solutions of the standard sugars were prepared by dissolving 10 mg sugar in 100 ml distilled water (0.01% solution). The standard curves were based on the values from gradual dilutions of the standard solution, to a total volume of 2.00 ml as follows (solution + water): 2.00 + 0.00; 1.5 + 0.50; 1.00 + 1.00; 0.50 + 1.50; 0.25 + 1.75 ; 0.00 + 2.00 ml.

### **3.2.3.3 Anthrone test and spectrophotometry.**

Anthrone reaction was done under cold (ice bath) and hot (boiling water bath) conditions. For test with cold anthrone solutions, standard sugars/plant extracts and anthrone were put into tubes in an ice bath and the reading on the spectrophotometer (630 nm) was taken when the tubes were completely cold. In the case of the hot anthrone test, after the addition of test standard/test solution and anthrone, the tubes were removed from the ice bath and transferred into a boiling water bath (90° C) for 7.5 minutes. They were subsequently placed in an ice bath for cooling, before spectrophotometer reading. Standard solutions and extracts from fresh plants were subjected to cold and hot anthrone, while extracts from the water phase of sequential extraction were tested with hot anthrone only.

### **3.2.3.4 Estimation of sugar concentration in water extracts from test plants**

Sugar concentration in test plants were referred to three sugar standards (fructose, glucose, sucrose). The optical densities read on the spectrophotometer were plotted against the corresponding concentrations for each standard sugar, thus determining the points for a standard curve (Figs. 7a-b). These points were used to generate a regression line whose equation ( $y = a + bx$ ) had computed coefficients used to determine the unknown values for the variable (x) when those of (y) corresponding to optical densities were available (Fig. 8a-b).

### 3.2.4 Bioassay for the assessment of attractancy/repellency of some of the plants tested for sandfly phytophagy

Attractancy and repellency are important factors in host-plant finding by insects. Since feeding is a result of an effective encounter, attractancy and repellency are the first steps to consider in studying the feeding behaviour of phytophagous insects (Lewis and van Emden, 1986).

Four plant species, *M. azedarach*, *O. suave*, *R. usambarensis* and *T. minuta*, were tested against a control (artificial plant ) for their attractancy/repellency to the sandfly *P. duboscqi*. Two-four day old flies of both sexes, unfed but provided with water for 24 hours before the test, were introduced into the release chamber from where they could enter (freely or assisted by a gentle blow with a mouth aspirator) the main chamber of the bioassay apparatus. The lower ends of the test plant materials were introduced into the holes (0.7 cm-diameter) perforated on the top side of a rectangular container (15.4 x 4.4 x 2.3 cm) provided with water. The containers with test materials were then placed into lateral chambers of the apparatus. Immediately before the introduction of bioassay materials, the water tap was opened, initiating the sucking in the suction system so that the air entering through the gates from outside could extract the odour from the test material, creating a gradient which was perceived by the test insects. The air flow was monitored through the flowmeter. The working range was 100-200 ml air per min, due to the fluctuation in the tap water flow. Reacting



to the odour from the plant material, insects could either orient to, land and stay in the area (especially on the netting material) surrounding the source (attractancy) or move to the opposite area (repellency). Those without a clear choice would keep hopping from one side to another or remain in the central (almost neutral) area of the main chamber and were referred to as non-responding individuals. The assay was conducted in a two-choice test (plant versus control, plant versus plant). The artificial plant used as a control was devoid of odour and presented almost the same colour as the test plant. Each test consisted in 5 replicates. The assays were conducted in a dark room except for the short recording period. This was done under dim light, realised by switching on the red tube above the apparatus and the distally located white tube. The tests were run at daytime (0700 - 1900) with recording every 5, 10, 15, 30, 45, 60, 120, 180, 360 and 720 min. However, *R. usambarensis* and *M. azedarach* were tested at both daytime and overnight. After each test, the components of the apparatus were washed and dried, and a fan air conditioner was used (the room being open) to extract residual odours.

### **3.2.5 Effects of plant diets on sandfly biology.**

The aim of this section was to assess the possible impact of plant diets on some determinant aspects of the biology of sandflies e.g., fecundity, developmental duration (life cycle), developmental survival, reproductivity and longevity. Since these biological attributes (particularly longevity) are likely to affect the vectorial capacity of the vector population, the following experiments were conducted to determine the extent of the influence of plant diets on (i) the fecundity (average number of eggs per female), (ii) hatchability (% number of larvae emerging from eggs), (iii) developmental survival (% number in one instar or stage over the number in the preceding instar or stage), (v) life cycle and developmental duration (number of days taken by developmental instar/stage/period and by the whole cycle from oogenesis to emergence, (vi) reproductivity (number of emerging adults per female laying eggs and number of emerging F<sub>1</sub> females per parental female and (vii) longevity (average life span of adults).

#### **3.2.5.1 Fecundity, life cycle, developmental survival and reproductivity**

A lot containing at least 100 females (with almost equal number of males (to ensure the fertility of the laid eggs) from the same batch were put into a feeding cage and given a hamster (for *P. duboscqi*) or a lizard (for *S. ingrami*). Hamsters were anaesthetised with Sagatal 0.2 ml while lizards were

restrained with a wire mesh. The hamsters were supplied by IABU/ICIPE while lizards were caught in the wild around Duduville, Kasarani, Nairobi. The cage was kept in an incubator: 3-5 hours were enough to have 90 - 100% females of *P. duboscqi* engorged; but females of *S. ingrami* needed at least 6 hours or were fed overnight. *P. duboscqi* was given a second meal after a 48-hour digestion time, in order to overcome gonotrophic discordance and provide a second opportunity to those individuals that did not feed during the first meal; *S. ingrami* appeared to be more gonotrophically concordant. Twenty-four hours after the single meal for *S. ingrami* or the second meal for *P. duboscqi*, gravid females were subdivided into 4 groups of at least 25 females which were kept for 24 hours (with an almost equal number of males) in different feeding cages containing four different diets (*R. usambarensis* and *S. incanum*, sugar and water). The total number in 5 replicates would definitely depend on the number of engorged females and the mortality during and after blood meal. Thus, the following numbers of female *S. ingrami* which had taken blood meals were given different diets: *R. usambarensis* (110), *S. incanum* (115), sucrose (123) and water (126). Their counterparts in the *P. duboscqi* groups were 112, 125, 120 and 121, respectively. After a 24-hour exposure to these diets in the different feeding cages, flies were transferred in pairs (1 female + 1 male) into individual oviposition vials; a group of vials containing flies from different cages were then inserted in different moisture retention containers. During oogenesis in females, the pair was maintained on the same diet as the one given after the female's blood meal; diet was introduced through the hole

made on the lid of the oviposition vial.

After oviposition, eggs laid by each individual female were counted and transferred into the rearing petri dish. The larval rearing system has been described by Beach *et al.*(1983). The rearing system was maintained in the incubator under temperature and humidity conditions described above. Oviposition was monitored, the eggs counted daily until the death of the last female. On the hatching of the first larvae, the rearing medium surface was sprinkled with a slight amount of larval food. This was increased as the number of larvae increased. The larval food was essentially composed of rabbit chow and rabbit feces ground together as described by Young *et al.* (1981), Mutinga *et al.*,(1989) and Perkins *et al.*(1991). Food supply was stopped once the pupation had started and when most of the larvae had reached the late fourth-instar. The most distinctive features in the different larval instars include : the number of caudal bristles (2 in first and 4 in subsequent instars), size of the head, size of the body, exuvium after each moult, etc (Dolmatova and Demina, 1971).

A dissecting microscope was used to daily check oviposition and count eggs, and to monitor hatching, development (moulting/metamorphosis) survival of larvae (from first to fourth instar) and pupae while the emergence of adults was observed by a naked eye. On the daily checking of the development and survival of immature stages much attention was paid to the presence of mites and fungi which are among the major handicaps to the laboratory colonisation of sandflies (Endris *et al.*,1984, Perkins *et al.*, 1991).

### 3.2.5.2 Longevity

Flies emerging from the same batch were put into one cage and kept for 24 hours in the incubator under the same conditions of temperature and humidity as those described in the feeding studies; after that period the weakest individuals died and were discarded. The lot of surviving flies was divided into 4 groups of 30 each ( $\pm 15$  females and  $\pm 15$  males); these were introduced into appropriate feeding cages where they were maintained on *R. usambarensis*, *S. incanum*, sucrose and water, separately. The experimental materials were kept in the incubator; mortality was checked and diets renewed daily until the death of the last fly in each cage.

### 3.2.6 Assessment of the effects of plant diets on *Leishmania* parasite infectivity

Four-week old BALB/c mice were infected with promastigotes of the *L. major* strain ICIPe 226 by intra-dermally inoculating a suspension of parasites (17,000 parasites per ml) through the mouth/nose, footpad and tail parts of the body. On the appearance of swelling and ulcer (histiocytoma) on the inoculated areas, infection was confirmed by the detection of parasites on a blood smear stained with Giemsa and observed under a compound microscope. Animals presenting signs of infection (sores on infected areas), gently immobilised with a soft wire mesh, were wrapped in an aluminium foil except for the exposed swollen mouth/nose area, and placed in a feeding cage containing a sample of fifty 2-4 day-old female *P. duboscqi*; flies were allowed to feed on the encaged mouse in an incubator at  $27.5 \pm 0.5^{\circ}\text{C}$  and 60 - 70% RH. After the feeding time (2-4 hours), the lot of flies was divided into 4 groups and distributed into 4 feeding cages containing the following diets, separately: *R. usambarensis*, *S. incanum*, sucrose, and water. From 48 hours after the infective blood meal, the dying females were removed from the cage and dissected in order to detect the presence of parasites; from the 4th day, dead flies and a given number ( $\pm 4$ ) of live ones were dissected daily until no more flies were left in the cage. The quality (expressed in terms of motility) and migration (in different regions of the gut) of parasites were noted during the dissection.

### **3.2.7 Data processing and analysis**

Lotus (123) and e-Editor were the most used Computer programmes for data recording and processing, the former having also a package for graphics. Graphs were done using Lotus (123), Harvard and Sigma Plot programmes. Most of the analyses were covered by the Statistical Analysis System (SAS) programme packages including mainly Analysis of Variance (ANOVA/GLM), for any significant difference among treatments, Student-Newman-Keuls (SNK) Test from Least Significant Difference (LSD) (for comparison of means) and Correlation Analysis to evaluate the degree of relationship between the investigated variables. In general, the results were presented in recording tables for a general view, graphical representation to depict the general patterns of the parameter under study and in statistical analysis tables to quantify the effect of the tested factors.

## CHAPTER 4

### RESULTS AND DISCUSSIONS

#### 4.1 Phytophagy

##### 4.1.1 Standardisation experiments

##### 4.1.1.1 Anthrone concentration

Table 1 summarises the performances of three concentrations, i.e. 1.00%, 1.25%, and 1.50% (w/v) of cold anthrone in detecting the presence of sugar in the gut of *S. ingrami* fed overnight on 10% sucrose. Of the 864 tested flies for each concentration, the following positive reactions were recorded: 457 (52.89%) with 0,100; 474 (54.86%) with 0.125; and 65 (53.82%) with 0.150. There is a slight difference (Table 1) among the three concentration but which was not found statistically significant ( $F = 0.23$ ;  $df = 2$ ;  $P > 0.05$ ). However, subsequent tests were be based on 1.25% concentration which appeared to yield a slightly higher mean.



Table 1:

Feeding rate of *S. ingrami* on sucrose as detected by three concentrations of cold anthrone.

Concentration	ND	% rate (Mean $\pm$ SE)
1.00	864	52.89 $\pm$ 2.23a
1.25	864	54.86 $\pm$ 2.05a
1.50	864	53.82 $\pm$ 2.10a

ND: Number of flies dissected;  
Means followed by the same letter are not significantly different at  $P \geq 0.05$ ; SE: Standard error.

#### 4.1.1.2 Exposure time

##### (a) Exposure period

Male and females of *S. ingrami* and *P. duboscqi* were fed on sucrose or and *R. usambarensis* during daytime and overnight, and the mean rates calculated after dissection were presented in Tables 2-5. Feeding rates were 51.74 and 56.71 when *S. ingrami* was fed on sucrose during daytime and overnight, respectively (Table 2). With *R. usambarensis*, the feeding rates were 53.24% and 61.92% for daytime and overnight exposure, respectively (Table 3). In both cases the feeding response seemed higher, but insignificant, in overnight exposure than during daytime ( $F = 2.16$ ;  $df = 1$ ;  $P > 0.05$ ) when the diet was sucrose (Table 2a) while a significant difference was observed ( $F = 5.46$ ;  $df = 1$ ;  $P < 0.05$ ) when the diet was *R. usambarensis* (Table 3). The feeding rates recorded with *P. duboscqi* offered sucrose were 59.59% during the day and 69.56% overnight; with *R. usambarensis*, the feeding rates were 51.16 and 56.13 % during daytime and overnight, respectively. As in *S. ingrami*, the overnight exposure was more favorable than the daytime one, but this time the significant difference was found with sucrose ( $F = 4.81$ ;  $df = 1$ ;  $P < 0.05$ ) (Table 4) while *R. usambarensis* was associated with an insignificant difference ( $F = 2.06$ ;  $df = 1$ ;  $P > 0.05$ ), (Table 5).

**Table 2:**

**Feeding rates of *S. ingrami* after daytime and overnight exposure to sucrose.**

Exposure period	ND	% rate (Mean $\pm$ SE)
Daytime	864	51.74 $\pm$ 2.27a
Overnight	864	56.71 $\pm$ 2.79a

ND: Number of flies dissected;  
Means followed by the same letter are not significantly different at  $P \leq 0.05$ ; SE: Standard error.

**Table 3:**

**Feeding rates of *S. ingrami* after daytime and overnight exposure to *R. usambarensis*.**

Exposure period	ND	% rate (Mean $\pm$ SE)
Daytime	864	53.24 $\pm$ 2.23b
Overnight	864	61.92 $\pm$ 3.08a

ND: Number of flies dissected;  
Means followed by different letters are significantly different at  $P \leq 0.05$ ;  
SE: Standard error.

**Table 4:**

**Feeding rates of *P. duboscqi* after daytime and overnight exposure to sucrose.**

Exposure period	ND	% rate (Mean $\pm$ SE)
Daytime	864	59.95 $\pm$ 3.17b
Overnight	864	69.56 $\pm$ 2.80a

ND: Number of flies dissected;  
Means followed by different letters are significantly different at  $P \leq 0.05$ ;  
SE: Standard error.

**Table 5:**

**Feeding rates of *P. duboscqi* after daytime and overnight exposure to *R. usambarensis*.**

Exposure period	ND	% rate (Mean $\pm$ SE)
Daytime	864	51.16 $\pm$ 2.35a
Overnight	864	56.13 $\pm$ 2.65a

ND: Number of flies dissected;  
Means followed by the same letter are not significantly different at  $P \geq 0.05$ ;  
SE: Standard error.

**(b) Exposure duration**

There is a high variability in the distribution of the feeding rates along the exposure period for each sandfly species with each diet, and for each diet with each sandfly species (Figs 1-4). When *S. ingrami* was fed on sucrose, the feeding rates varied from 31.94% (1 hr exposure) to 70.83% (15 hr) while those of *P. duboscqi* ranged from 34.72% (24 hr) to 87.50% (18 hr). When both sandfly species were given *R. usambarensis*, *S. ingrami* had the lowest value at 3-4hr (40.28%) and the highest at 18 hr (75%) whereas *P. duboscqi*'s varied from 38.89% (2 hr) to 69.44% (13 hr). Sex did not significantly affect the feeding rate.

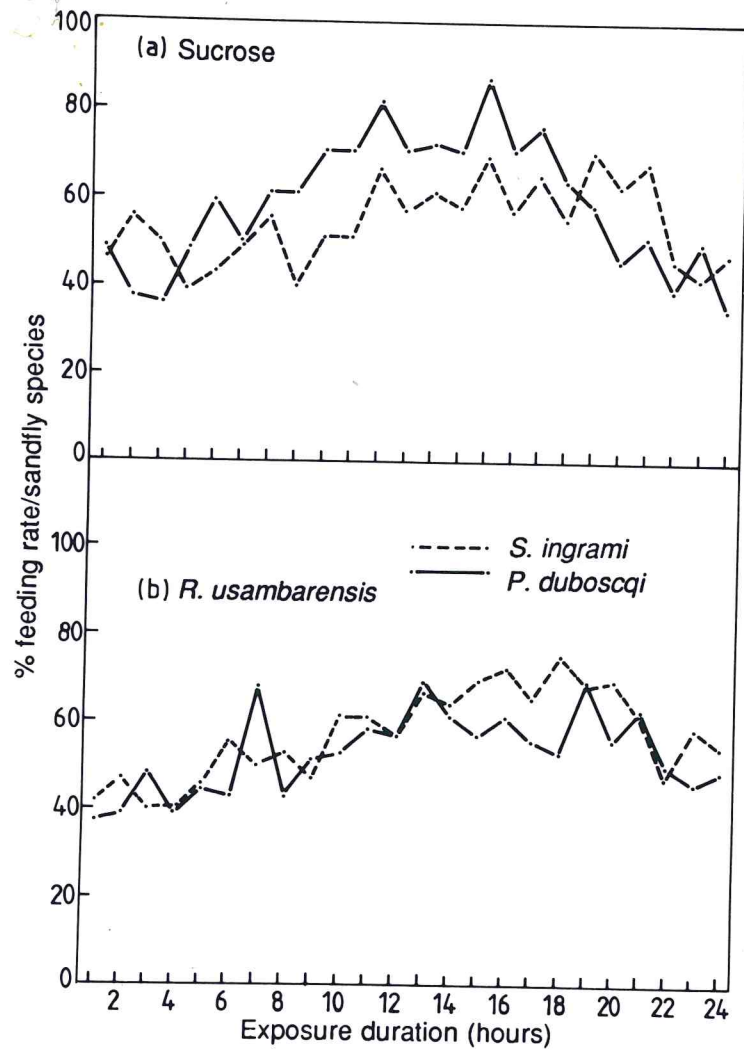

Figure 1a-b: Feeding rates of *S. ingrami* and *P. duboscqi* on sucrose (a) and *R. usambarensis* (b) through a 24-hour exposure period with a 1-hour dissection interval.

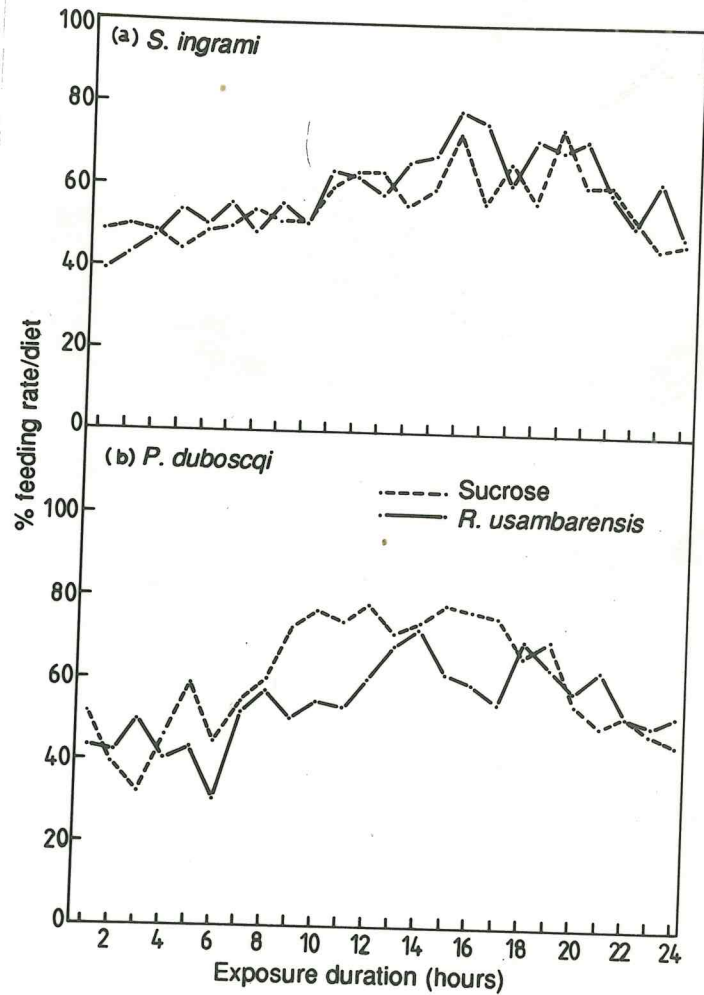

Figure 2a-b: Feeding rates on sucrose and *R. usambarensis* by *S. ingrami* (a) and *P. duboscqi* (b) through a 24-hour exposure period with a 1-hour dissection interval.

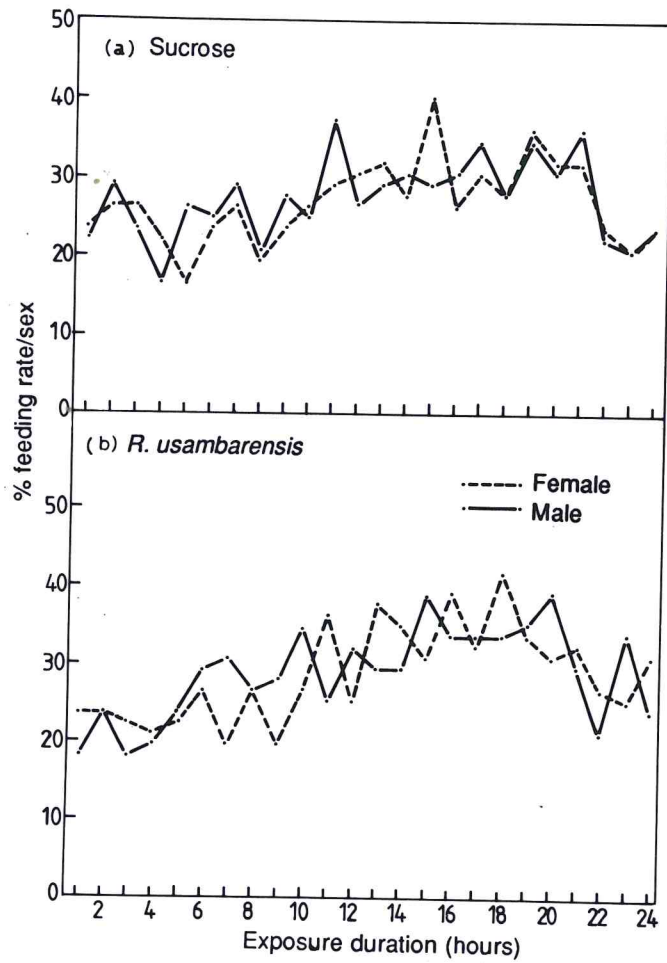

Figure 3a-b: Feeding rates in both sexes of *S. ingrami* on sucrose (a) and *R. usambarensis* (b) through a 24-hour exposure with a 1-hour period dissection interval.



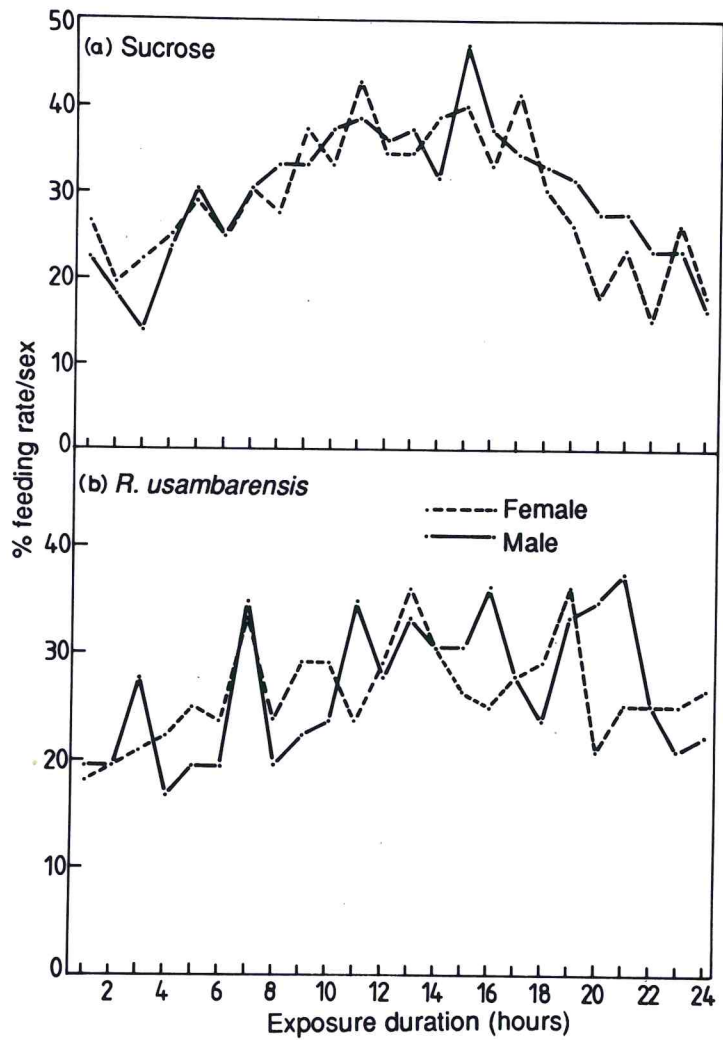

Figure 4a-b: Feeding rates in both sexes of *P. duboscqi* on sucrose (a) and *R. usambarensis* (b) through a 24-hour exposure period with a 1-hour dissection interval.

#### 4.1.1.3 Feeding preference

When both *S. ingrami* and *P. duboscqi* were offered simultaneously the same diet (Tables 6-8), the former showed a higher mean feeding rate with *R. usambarensis* (57.12%) than did *P. duboscqi* (52.95%) ( $F = 6.50$ ;  $df = 1$ ;  $P < 0.05$ ). In contrast *P. duboscqi* seemed to respond more to sucrose (59.09%) than did *S. ingrami* (54.44) (Table 6) ( $F = 4.91$ ;  $df = 1$ ;  $P < 0.05$ ).

In the case where a single sandfly species was given two diets in two simultaneous experiments, *S. ingrami* did not show a significant preference between sucrose (56.13%) and *R. usambarensis* (59.03%) ( $F = 3.08$ ;  $df = 1$ ;  $P > 0.05$ ) while *P. duboscqi* appeared to prefer sucrose (59.95%) to *R. usambarensis* (53.76) (Table 7) ( $F = 10.98$ ;  $df = 1$ ;  $P < 0.05$ ).

The feeding rates by sex did not show a significant difference in the feeding response between sexes in any of the two sandfly species and for any of the two diets (Table 8).

Table 6:

Feeding rates of *S. ingrami* and *P. duboscqi* when both were offered either sucrose or *R. usambarensis*.

Diet	Sandfly species	ND	% rate (Mean $\pm$ SE)
Su	<i>S. ingrami</i>	1728	54.44 $\pm$ 1.44b
Su	<i>P. duboscqi</i>	1728	59.09 $\pm$ 2.01a
Ru	<i>S. ingrami</i>	1728	57.12 $\pm$ 1.68a
Ru	<i>P. duboscqi</i>	1728	52.95 $\pm$ 1.52b

Su: Sucrose; Ru: *R. usambarensis*;

ND: Number of flies dissected ;

Means followed by the same letter are not significantly different at  $P \geq 0.05$ ; SE: Standard error.

Table 7:

Feeding rates of *S. ingrami* and *P. duboscqi* when each was offered sucrose and *R. usambarensis*

Diet	Sandfly species	ND	% rate (Mean $\pm$ SE)
Su	<i>S. ingrami</i>	1728	56.13 $\pm$ 1.36a
Ru	<i>S. ingrami</i>	1728	59.03 $\pm$ 1.64a
Su	<i>P. duboscqi</i>	1728	59.95 $\pm$ 1.91a
Ru	<i>P. duboscqi</i>	1728	53.76 $\pm$ 1.48b

Ru: *R. usambarensis*; Su: Sucrose;

ND: Number of flies dissected; Means followed by the same letter are not significantly different at  $P \geq 0.05$ ; SE: Standard error.

Table 8:

Feeding rates by sex when *S. ingrami* and *P. duboscqi* were given sucrose and *R. usambarensis*.

Diet	Sandfly species	ND	% rate (Mean $\pm$ SE)	
			Female	Male
Su	<i>S. ingrami</i>	1728	26.96 $\pm$ 0.60a	27.48 $\pm$ 0.61a
Ru	<i>S. ingrami</i>	1728	28.53 $\pm$ 0.70a	28.59 $\pm$ 0.73a
Su	<i>P. duboscqi</i>	1728	29.86 $\pm$ 0.91a	29.22 $\pm$ 0.22a
Ru	<i>P. duboscqi</i>	1728	26.86 $\pm$ 0.55a	26.27 $\pm$ 0.75a

Su; Sucrose; Ru: *R. usambarensis*;

ND: Number of flies dissected;

Horizontal means followed by the same letter are not significantly different at  $P \geq 0.05$ ; SE: Standard error.

#### 4.1.1.4 Discussion

The anthrone test was performed as described by Young *et al.* (1980) but with some modifications, dictated by logistic and practical considerations. For example, preliminary trials using the locally available anthrone (sold by Howse and McGeorge, Nairobi) at the concentration of 0.1% according to the above workers either failed completely to detect the presence of sugar or gave a very faint blue colour. Indeed, the label on the container of the product from Howse and McGeorge indicates 1% as the minimum sensitivity to sucrose. After trials with 1.00%, 1.25% and 1.50%, the intermediate concentration although it did not yield a significantly higher performance, was chosen for further tests, because it had a slightly higher mean rate and a relatively lower variability.

In general, the feeding response was higher when both *S. ingrami* and *P. duboscqi* were given the diet overnight. However, the degree of the difference seemed to be diet-dependent: it was more pronounced with *S. ingrami* fed on *R. usambarensis* than on sucrose while the difference for *P. duboscqi* was higher when the latter was given sucrose than *R. usambarensis*.

These results are consistent with the findings by Schlein and Warburg (1986) from their studies on *P. papatasi* fed on *Capparis spinosa* (Capparaceae). In this experiment, flies fed more at night than during daytime, whether under artificial light or in darkness. The photoperiodic rhythm is an evolutionary trait which persists although this sandfly species

breeds and rests in *Psammomys obesus*' burrows where the darkness prevails irrespective of the nycthemeral period. And likely the same remark would apply to *S. ingrami* and *P. duboscqi*, especially the latter for which *Tatera*'s burrow is the breeding and resting site in Baringo focus (its main distribution areas in Kenya) (Kaddu, 1986; Mutinga, 1990).

The high variability of the feeding rates within an exposure period made it impossible to determine the exact duration for a maximum feeding rate for a given species and diet. Since the high feeding peaks occurred mainly between 6 and 19 hours, an overnight exposure the range 10-16 hours is recommended. Schlein and Warburg (1986) exposed flies within a similar range, while Kaddu *et al.* (1992) adopted a 16-hour exposure.

The similarity in feeding responses of males and females of each species in terms of time and diet indicates that both sexes are adapted to imbibing (sugar, water drinking mode) or probing and sucking (blood, plant feeding mode) (Schlein *et al.* 1986).

When *S. ingrami* and *P. duboscqi* were given the same diet at the same time, the former showed a higher feeding rate on *R. usambarensis*, whereas the latter fed more on sucrose than did the former. On the other hand, when each of the sandflies was offered sucrose and *R. usambarensis*, *S. ingrami* slightly, but not significantly preferred *R. usambarensis* to sucrose, while *P. duboscqi*'s preference was significantly higher for sucrose. Kaddu *et al.* (1992) found *S. ingrami* to be a highly polyphytophagous insect; more tests were needed for *P. duboscqi* in order to appreciate its real phytophagy spectrum.

**4.1.2 Feeding rate and performance with reference to carbohydrates in *S. ingrami* and *P. duboscqi* offered different plant species, sucrose and water.**

**4.1.2.1 *S. ingrami***

**(a) Feeding rate**

There is a highly significant heterogeneity ( $F = 68.99$ ;  $df = 8$ ;  $P < 0.001$ ) in the feeding rates on the different diets (Fig.5; Appendix 1). The highest rate was on *R. usambarensis* (60.74%), followed by *M. azedarach* (56.60%) and sucrose (55.21%); the lowest were on water (0.00%), *T. minuta* (2.78%), *O. suave* (11.81%) and *O. kenyense* (20.83%). On *S. incanum* and *A. indica*, the feeding rates were in the 25 - 50% range.

The feeding rates on different parts of *S. incanum* (Table 9) were almost similar, except on the fruit when the peduncle was excised and the wound sealed (fruit<sub>1</sub>: 0.00%). The highest value (30.21%) was observed with the flower which had been completely isolated from the other parts.



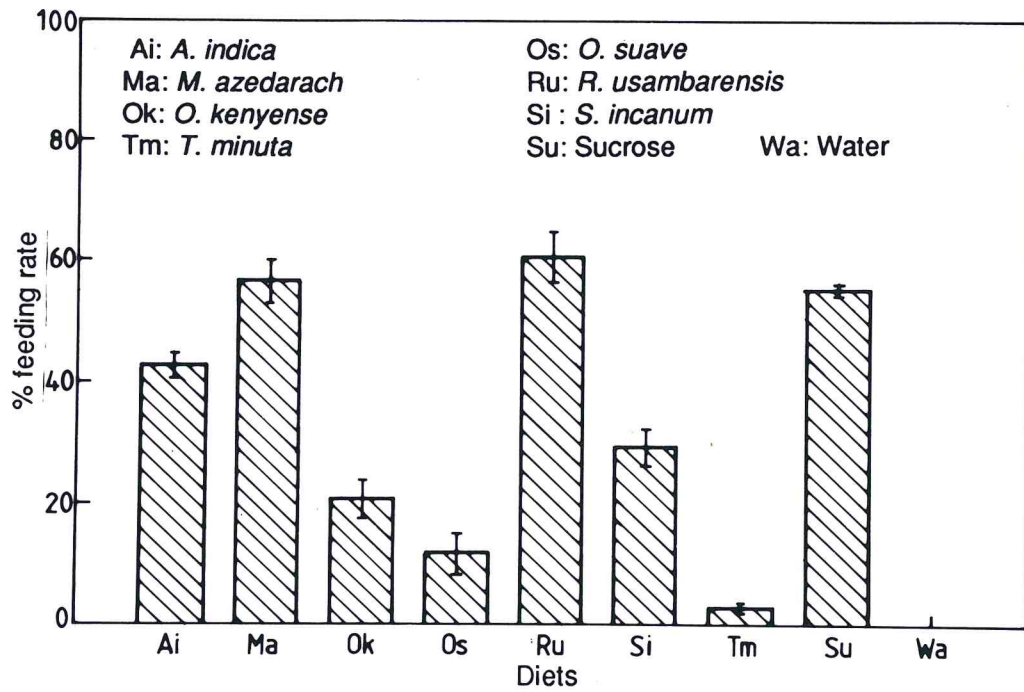

Figure 5: Feeding rates of *S. ingrami* on various plant species, sucrose and water.

Table 9:

Feeding rates of *S. ingrami* on different parts of *S. incanum*.

Part	ND	% rate (Mean $\pm$ SE)
Leaves	288	29.31 $\pm$ 4.48a
Flower <sub>1</sub>	288	30.21 $\pm$ 2.18a
Flower <sub>2</sub>	288	27.78 $\pm$ 2.78a
Fruit <sub>1</sub>	288	0.00 $\pm$ 0.00b
Fruit <sub>2</sub>	288	26.39 $\pm$ 2.20a
Whole	288	27.43 $\pm$ 7.24a

Flower<sub>1</sub>: Flower completely isolated ; Flower<sub>2</sub>: Flower not completely isolated; Fruit<sub>1</sub>: Fruit whose peduncle was excised and the wound sealed; Fruit<sub>2</sub>: Fruit whose peduncle was excised and the wound sealed; ND: Number of flies dissected; Means followed by the same letter are not significantly different at  $P \geq 0.05$ ; SE: Standard error

**(b) Feeding performance**

The feeding performance at different levels (D, M, F) of the pooled diets were dominated by the lowest level (F) with 23.92%, followed by the intermediate level (M) with 7.64%; the last was at the highest level (D) with 3.17%. The high variability among the feeding levels within the pooled diets (Table 10) reflects the variability at the individual diet level (Table 11). Among individual diets, the highest feeding intensity was observed in the flies given sucrose (7.99%) followed by those fed on *R. usambarensis* (6.60) and *A. indica* (6.60%); the lowest values were on *O. suave* (0.00%) and *T. minuta* (0.00%). The feeding performance was affected by (i) the diet ( $F = 28.46$ ;  $df = 7$ ;  $P \leq 0.001$ ), the feeding level ( $F = 176,21$ ;  $df = 2$ ;  $P \leq 0.001$ ) and (iii) their interaction ( $F = 5.08$ ;  $df = 14$ ;  $P \leq 0.001$ ). There was a significant variability among diets at each feeding level (Table 11; Appendix 3).

Table 10:

Overall mean feeding performance of *S. ingrami* on different plant species and sucrose (all diets pooled together).

Level	N	% rate (Mean $\pm$ SE)
D	96	3.17 $\pm$ 0.55c
M	96	7.64 $\pm$ 1.02b
F	96	23.92 $\pm$ 1.57a

D: Deep blue colour intensity; M: Medium blue colour intensity;

F: Faint blue colour intensity;

N: Total number of experiments (8 diets in 12 replicates);

Means followed by the same letter are not significantly different at  $P \geq 0.05$ ; SE: Standard error.

Table 11:

Feeding performance of *S. ingrami* on different plant species and sucrose (by individual diet).

Diet	N	% rate (Mean ± SE)		
		Levels		
		D	M	F
Ai	12	6.60 ± 0.95ab	11.11 ± 1.18b	25.00 ± 0.05ab
Ma	12	2.43 ± 1.30bc	16.67 ± 2.66ab	34.38 ± 3.88a
Ok	12	0.35 ± 0.35c	0.69 ± 0.47c	19.79 ± 3.17bc
Os	12	0.00 ± 0.00	0.35 ± 0.35c	11.46 ± 4.26cd
Ru	12	6.60 ± 2.14ab	17.36 ± 4.50a	36.81 ± 3.11a
Si	12	1.39 ± 0.78c	2.78 ± 0.94c	25.35 ± 3.14ab
Tm	12	0.00 ± 0.00c	0.00 ± 0.00c	35.07 ± 1.13d
Su	12	7.99 ± 2.43a	12.15 ± 2.64ab	35.07 ± 2.74a

Ai: *A. indica*; Ma: *M. azedarach*; Ok: *O. kenyense*; Os: *O. suave*; Ru: *R. usambarensis*; Si: *S. incanum*; Tm: *T. minuta*; Su: sucrose;  
D: Deep blue colour intensity; M: Medium blue colour intensity; F: Faint blue colour intensity; N: Number of experiments;  
Vertical means followed by the same letter are not significantly different at  $P \geq 0.05$ ; SE: Standard error.

#### 4.1.2.2 *P. duboscqi*

##### (a) Feeding rate

The results on the feeding response by *P. duboscqi* on different diets show a high degree of variability in feeding rates ( $F = 106.78$ ;  $df = 8$ ;  $P \leq 0.001$ ). In general, *M. azedarach* had the highest rate (82.99%), followed by sucrose (70.49%) and *R. usambarensis* (55.56%); the lowest rate (0.35%) was obtained with water, while *T. minuta* (1.39%) was the least preferred among the plants (Fig. 6; Appendix 2).

There was a significant difference in responses to young and old leaves of *M. azedarach* ( $F = 28.99$ ;  $df = 1$ ;  $P \leq 0.001$ ); the mean feeding rates were being 82.99% and 38.19% for young and old leaves respectively (Table 12).

When the same species was offered different parts of *S. incanum*, the lowest rate (1.39%) was observed on the fruit with the peduncle excised and the wound sealed (Table 13). The rates on the other parts were homogenous in the range 26.04 - 34.03 %.

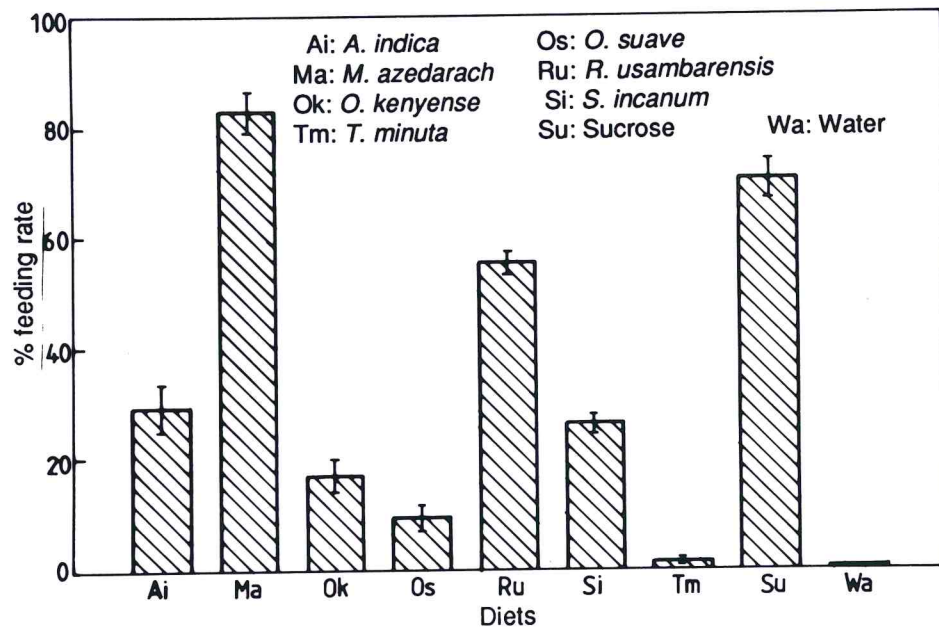

Figure 6: Feeding rates of *P. duboscqi* on various plant species, sucrose and water.

**Table 12:**

**Feeding rates of *P. duboscqi* on young and old leaves of *M. azedarach*.**

Age	ND	% rate (Mean $\pm$ SE)
Young	288	92.99 $\pm$ 3.64a
Old	288	38.19 $\pm$ 6.32b

ND: Number of flies dissected;

Means followed by different letters are significantly different at  $P \leq 0.05$ ;

SE: Standard error.

**Table 13:**

**Feeding rates of *P. duboscqi* on different parts of *S. incanum*.**

Part	ND	% rates (Mean $\pm$ SE)
Leaves	288	27.78 $\pm$ 2.45a
Flower <sub>1</sub>	288	26.04 $\pm$ 1.71a
Flower <sub>2</sub>	288	26.04 $\pm$ 2.95a
Fruit <sub>1</sub>	288	1.39 $\pm$ 0.94b
Fruit <sub>2</sub>	288	34.03 $\pm$ 4.16a
Whole	288	26.39 $\pm$ 1.73a

Flower<sub>1</sub>: Flower completely isolated; Flower<sub>2</sub>: Flower not completely isolated;  
 Fruit<sub>1</sub>: Fruit whose peduncle was excised and the wound sealed; Fruit<sub>2</sub>: Fruit  
 whose peduncle was excised and the wound unsealed; ND: Number of flies  
 dissected;

Means followed by the same letter are not significantly different at  $P \geq 0.05$ ;  
 SE: Standard error.



**(b) Feeding performance**

The feeding performance of *P. duboscqi* on the pooled diets is highly variable; the dominant proportion of 21.44% was at the lowest level (F), followed by 8.25% at the intermediate level (M), and the lowest (6.94%) at the highest level (D) (Table 14). This trend was also observed in the heterogeneity among individual diets (Table 15). The highest value (32.97%) was on *M. azedarach*, while *T. minuta* was the least fed upon among the plants (0.00%). As in *S. ingrami*, the feeding performance of *P. duboscqi* was significantly affected by (i) the diet ( $F = 59.21$ ;  $df = 7$ ;  $P < 0.001$ ), (ii) the feeding level ( $F = 102.42$ ;  $df = 2$ ;  $P < 0.001$ ) and (iii) their interaction ( $F = 9.15$ ;  $df = 14$ ;  $P < 0.001$ ). The distribution of feeding levels was highly variable among the different diets (Appendix 4).

**Table 14:**

**Overall mean feeding performance of *P. duboscqi* on different plant species and sucrose (all diets pooled together).**

Level	N	% rate (Mean $\pm$ SE)
D	96	6.94 $\pm$ 1.27b
M	96	8.25 $\pm$ 1.11b
F	96	21.44 $\pm$ 1.58a

D: Deep blue colour intensity; M: Medium blue colour intensity; F: Faint blue colour intensity;

N: Total number of experiments (8 diets in 12 replicates);

Means followed by the same letter are not significantly different at  $P \geq 0.05$ ;

SE: Standard error.

**Table 15:**

**Feeding performance of *P. duboscqi* on different plant species and sucrose (by individual diet).**

Diet	N	% rate (Mean $\pm$ SE)		
		Levels		
		D	M	F
Ai	12	0.69 $\pm$ 0.69cd	2.43 $\pm$ 0.95c	25.69 $\pm$ 3.90b
Ma	12	32.97 $\pm$ 4.54a	22.93 $\pm$ 2.88a	27.43 $\pm$ 3.50b
Ok	12	1.39 $\pm$ 0.78cd	0.69 $\pm$ 0.47c	14.93 $\pm$ 2.38c
Os	12	0.69 $\pm$ 0.47cd	2.43 $\pm$ 1.74c	6.25 $\pm$ 1.08d
Ru	12	8.33 $\pm$ 1.99bc	15.28 $\pm$ 1.80b	32.64 $\pm$ 2.17b
Si	12	1.39 $\pm$ 0.78cd	2.43 $\pm$ 0.80c	22.57 $\pm$ 1.81bc
Tm	12	0.00 $\pm$ 0.00d	0.00 $\pm$ 0.00c	1.39 $\pm$ 4.04d
Su	12	10.07 $\pm$ 2.14b	19.79 $\pm$ 3.77ab	40.63 $\pm$ 0.59a

Ai: *A. indica*; Ma: *M. azedarach*; Ok: *O. kenyense*; Os: *O. suave*; Ru: *R. usambarensis*; Si: *S. incanum*; Tm: *T. minuta*; Su: Sucrose;  
 N: Number of experiments (by diet);  
 D: Deep blue colour intensity; M: Medium blue colour intensity; F: Faint blue colour intensity;  
 Vertical means followed by the same letter are not significantly different at  $P \geq 0.05$ ; SE: Standard error.

#### 4.1.2.3 Discussion

*S. ingrami* and *P. duboscqi* showed a very strong selectivity towards the different test plants. *R. usambarensis* and *M. azedarach* were the most preferred although the latter plant was more preferred by *P. duboscqi* than by *S. ingrami*; preference for *R. usambarensis* was higher in *S. ingrami*. These two plants and sucrose were the most suitable, based on feeding rates (>50%); *A. indica* and *S. incanum* were in the intermediate range (25 - 50%). *O. kenyense*, *O. suave* and *T. minuta* elicited the poorest feeding responses, slightly above water (negative control). The feeding rate of 0.35% recorded for *P. duboscqi* on water might be attributed to contamination. A similar selective phytophagy was reported on *P. papatasi* by Schlein and Warburg (1986) in Israel. They tested 18 plant species; only 5 provided an average rate higher than 50%, and the highest rate was on *C. spinosa*.

The feeding performance (D and M levels) on pooled replicates of plants and sucrose was slightly higher in *P. duboscqi* (D = 6.94%, M = 8.25%, F = 21.44%) than in *S. ingrami* (D = 3.17%, M = 7.64%, F = 23.93%). The most important sugar sources for *P. duboscqi* were *M. azedarach*, sucrose and *R. usambarensis*, while the best sources for *S. ingrami* were sucrose, *A. indica* and *R. usambarensis*.

With reference to sucrose (spectrophotometry at 630 nm), the three levels of blue colour intensity fit approximately into the following ranges of optical densities: D: optical density  $\geq 1.40$ ; M: optical density (0.80 - 1.40 and F: optical density  $\leq 0.80$ . These colour intensity levels

coincide with the three degrees of satiation defined by Chaniotis (1974) with *Lu. trapidoi* fed on sucrose. They are: S (slight), traces of sugar in the abdomen; M (medium), sugar filling a substantial part of abdomen but producing no distension and L (large), sugar filling and distending the abdomen. In the present study, the high level of colour intensity was generally associated with the distension of the abdomen. A test based on the sum of D and M revealed a positive correlation ( $R = 0.82412$ ;  $P < 0.001$ ) between feeding rate and feeding intensity in general but not always reflecting individual contribution. This suggests that for a given species feeding on different diets, the higher feeding rate is not necessarily associated with the higher feeding performance.

It was surprising that both species fed relatively well on *A. indica* and *M. azedarach*, which have been recorded as having strong anti-feedant property to several insect species (Lee *et al.*, 1991). On the other hand, *S. incanum* reported to be poisonous to animals (Watt, 1962) including insects (Schlein, 1986) provided a feeding rate of 25 - 50% to both *S. ingrami* and *P. duboscqi*. But such kinds of biotypes have often been encountered (Smith, 1989).

Similar feeding rates in *S. ingrami* and *P. duboscqi* were obtained on the different parts of *S. incanum*. The extremely low feeding rates on fruits with peduncle excised and wound sealed, in contrast to the high rates on those with unsealed wounds indicates that the exudate may be attractant and/or the waxy surface of the fruit may be too hard for sandfly mouthparts.

The difference in feeding rates on old and young leaves of *M. azedarach* may be due to physical barrier (hardness) as in the fruit of *S. incanum*; it may also be related to differences in chemical composition between the growing and the aging leaves (Metcalf and Metcalf, 1992).

## **4.2 Sugar content in the test plants**

### **4.2.1 Anthrone test and spectrophotometry**

#### **4.2.1.1 Standard sugars**

Solutions of increasing standard sugar concentrations read on the spectrophotometer, after the anthrone test, gave the corresponding optical densities for each sugar at each temperature (Table 16).

Tables 17 and 18 report optical densities under sugar and temperature as source of variation, respectively. Fructose and sucrose were not significantly different (Appendix 5) in their sensitivity at both cold and hot temperature; glucose apparently reacts more readily with hot than cold anthrone. In general, the output of the spectrophotometry was significantly affected by (i) the standard sugar ( $F = 374.47$ ;  $df = 2$ ;  $P < 0.001$ ), (ii) the temperature ( $F = 11.07$ ;  $df = 1$ ;  $P < 0.05$ ) and (iii) their interaction ( $F = 9.37$ ;  $df = 2$ ;  $P < 0.05$ ). The effects of temperature on each individual sugar is analysed in Appendix 5.

**Table 16:**

**Optical density (spectrophotometry at 630 nm) of standard sugars with increasing concentration.**

Conc (mg/ml)	Optical density					
	Fructose		Glucose		Sucrose	
	Cold	Hot	Cold	Hot	Cold	Hot
0.0000	0.000	0.000	0.000	0.000	0.000	0.000
0.0125	0.284	0.216	0.012	0.167	0.202	0.285
0.0250	0.502	0.512	0.083	0.263	0.578	0.549
0.0500	0.980	0.892	0.103	0.357	0.631	0.654
0.0750	1.374	1.435	0.108	0.437	1.287	1.194
0.1000	1.897	2.015	0.273	0.509	1.476	1.524

Conc: Concentration



**Table 17:**

**Effect of standard sugar type on the optical density measured after test of different concentrations with cold and hot anthrone.**

Sugar	N	% (Mean ± SE)	
		Cold	Hot
Fructose	6	0.839 ± 0.202a	0.845 ± 0.313a
Glucose	6	0.097 ± 0.039b	0.289 ± 0.076b
Sucrose	6	0.696 ± 0.238a	0.701 ± 0.232a

N: Number of concentration levels;  
Vertical means followed by the same letter are not significantly different at  $P \geq 0.05$ ; SE: Standard error.

**Table 18:**

**Effect of temperature on the sensitivity of individual standard sugar to anthrone test.**

Temp	N	% (Mean ± SE)		
		Fructose	Glucose	Sucrose
Cold	6	0.839 ± 0.292a	0.097 ± 0.039b	0.696 ± 0.238a
Hot	6	0.845 ± 0.313a	0.289 ± 0.076a	0.701 ± 0.232a

Temp: Temperature; N: Number of concentration levels;  
Vertical means followed by the same letter are not significantly different at  $P \geq 0.05$ ; SE: Standard error.

#### 4.2.1.2 Water extracts

##### (a) Extracts by direct extraction of fresh plant materials.

Table 19 presents optical densities of the extracts from fresh plant materials measured at their respective optimal volume after treatment with cold and hot anthrone. The results of these trials show a high variability in the sensitivity of different plant species to anthrone test; the most sensitive species (*A. indica*, *T. minuta*) responded at low volumes, while the least sensitive (*O. suave*, *S. incanum*) required high volumes of extracts for a readable positive reaction with anthrone. As it appears in the Table 20, the sensitivity of the reaction with anthrone reagent was not significantly affected by the temperature.

##### (b) Extracts in water phase of sequential extraction

Sequential plant water extracts tested with hot anthrone have their optical densities recorded in Table 21. The sensitivity of anthrone reactions ranged between 0.177% (*O. suave*) and 0.612% (*O. kenyense*). It is interesting to note that the lower and the higher limits were recorded from plants of the same genus (*Ocimum*). The anthrone test with extracts from different plant species showed a high variability (  $F = 66.43$ ;  $df = 6$ ;  $P < 0.001$ ).

Table 19:

Optical density of water extracts from fresh plant materials after test with cold and hot anthrone.

Rep	Plant species													
	Ai (0.1 ml)		Ma (1.0 ml)		Ok (1.0 ml)		Os (5.0 ml)		Ru (1.0 ml)		Si (2.0 ml)		Tm (0.2ml)	
	Cold	Hot	Cold	Hot	Cold	hot	Cold	Hot	Cold	Hot	Cold	Hot	Cold	Hot
1	0.352	0.841	0.896	0.998	1.576	1.175	0.243	0.244	0.777	1.046	1.028	1.357	0.868	1.075
2	0.726	0.816	1.031	1.012	1.466	1.171	0.223	0.238	0.781	1.071	1.328	1.473	1.002	1.015
3	0.762	0.909	0.968	1.008	1.483	1.194	0.231	0.285	0.773	0.890	1.811	1.477	1.229	0.988
4	0.634	0.868	1.001	1.038	1.451	1.219	0.262	0.231	0.762	0.824	1.668	1.339	0.512	1.001
5	0.655	0.885	1.027	1.028	1.423	1.181	0.226	0.126	0.772	1.075	1.019	1.402	1.141	0.979

Rep: Replicate; Ai: *A. indica*; Ma: *M. azedarach*; Ok: *O. kenyense*; Os: *O. suave*; Ru: *R. usambarensis*;

Si: *S. incanum*; Tm: *T. minuta*;

() : Optimum volume for the sensitivity of anthrone test and according to the range of optical densities recorded with standard sugars.

**Table 20:**

**Effect of temperature on the sensitivity of water extracts from fresh plant materials to anthrone reagent.**

Temperature	N	% (Mean $\pm$ SE)
Cold	35	0.917 $\pm$ 0.074a
Hot	35	0.957 $\pm$ 0.059a

N: Total number of experiments (7 plants in 5 replicates);  
Means followed by the same letter are not significantly different at  $P \geq 0.05$ ;  
SE: Standard error.

**Table 21:**

**Optical density of water extracts from plant materials after sequential extraction and test with hot anthrone.**

Plant species	N	% (Mean $\pm$ SE)
Ai	5	0.234 $\pm$ 0.018e
Ma	5	0.496 $\pm$ 0.017b
Ok	5	0.612 $\pm$ 0.020a
Os	5	0.177 $\pm$ 0.006f
Ru	5	0.315 $\pm$ 0.026d
Si	5	0.428 $\pm$ 0.024c
Tm	5	0.462 $\pm$ 0.013bc

Ai: *A. indica*; Ma: *M. azedarach*; Ok: *O. kenyense*; Os: *O. suave*;  
Ru: *R. usambarensis*; Si: *S. incanum*; Tm: *T. minuta*;  
N: Number of experiments for each plant;  
Means followed by the same letter are no significantly different at  $P \geq 0.05$ ; SE: Standard error.

#### 4.2.2 Sugar concentration

Sugar concentration in the test plants were expressed in terms of equivalents of the standard sugars, i.e fructose, glucose and sucrose. The optical densities plotted against the corresponding concentrations defined a standard curve (Figs 7a-b) from which a regression line (Figs 8a-b) provided coefficients for a linear equation ( $y = a + bx$ ). The concentration ( $x$ ) was calculated using the above equation where the values of  $y$ ,  $a$  and  $b$  were known.

#### 4.2.2.1 Sugar concentration in water extracts by direct extraction of fresh plant materials

##### (a) Fructose equivalent

Fructose constituent of the extracts from different plants were estimated after treatment with cold and hot anthrone and the results reported in Table 22. *A. indica* (0.64%) and *T. minuta* (0.50%) were apparently far the richest in fructose, followed by *O. kenyense* (0.10%); *O. suave* with 0.01% had the lowest concentration. In overall, hot anthrone yielded more fructose (0.26%) than did cold anthrone (0.22%) (Table 23). Both plant species ( $F = 203.53$ ;  $df = 6$ ;  $P < 0.001$ ), temperature ( $F = 5.90$ ;  $df = 1$ ;  $P < 0.05$ ), and their interaction ( $F = 5.76$ ;  $df = 6$ ;  $P < 0.001$ ) affected significantly the sensitivity of anthrone test for fructose.

**Table 22:**

**Mean Concentration (w/w) in fructose equivalent by plant species for each temperature.**

Plant species	N	% (Mean $\pm$ SE)	
		Cold	Hot
Ai	5	0.64 $\pm$ 0.0780a	0.89 $\pm$ 0.0158a
Ma	5	0.10 $\pm$ 0.0026cd	0.11 $\pm$ 0.0007cd
Ok	5	0.16 $\pm$ 0.0029c	0.12 $\pm$ 0.0009c
Os	5	0.01 $\pm$ 0.0008f	0.01 $\pm$ 0.0005f
Ru	5	0.08 $\pm$ 0.0003cd	0.10 $\pm$ 0.0052d
Si	5	0.07 $\pm$ 0.0087cd	0.07 $\pm$ 0.0014e
Tm	5	0.50 $\pm$ 0.0678	0.52 $\pm$ 0.0084b

Ai: *A. indica*; Ma: *M. azedarach*; Ok: *O. kenyense*; Os: *O. suave*; Ru: *R. usambarensis*; Si: *S. incanum*; Tm: *T. minuta*;  
 N: Number of experiments for each plant species;  
 Vertical means followed by the same letter are not significantly different at  $P \geq 0.05$ ; SE: Standard error.



**Table 23:**

**Overall mean concentration (w/w) in fructose equivalent for each temperature.**

Temperature	N	% (Mean $\pm$ SE)
Cold	35	0.22 $\pm$ 0.04b
Hot	35	0.26 $\pm$ 0.05a

N: Total number of experiments (7 plants in 5 replicates);  
Means followed by different letters are significantly different at  
P < 0.05; SE: Standard error.

**(b) Glucose equivalent**

In both media (cold and hot anthrone), *A. indica* and *T. minuta* were the most dominant for sugar concentration with 5.379 % versus 7.397% and 4.071 versus 4.339%, respectively. Apart from *O. kenyense*, the other test plants were below 1 %, with *O. suave* being the lowest (Table 24).

In general, hot anthrone was more efficient (2.17%) in detecting glucose than was cold anthrone (1.84%) (Table 25). The concentration was significantly influenced by both the plant species ( $F = 223.26$ ;  $df = 6$ ;  $P < 0.0001$ ) and the temperature ( $F = 7.68$ ;  $df = 1$ ;  $P < 0.05$ ).

**Table 24:**

**Mean concentrations (w/w) in glucose equivalent of plant species at each temperature.**

Plant species	N	% (Mean $\pm$ SE)	
		Cold	Hot
Ai	5	5.379 $\pm$ 0.615a	7.397 $\pm$ 0.134a
Ma	5	0.843 $\pm$ 0.021cd	0.871 $\pm$ 0.006c
Ok	5	1.265 $\pm$ 0.022c	1.016 $\pm$ 0.007c
Os	5	0.041 $\pm$ 0.001d	0.039 $\pm$ 0.004e
Ru	5	0.664 $\pm$ 0.003cd	0.840 $\pm$ 0.044cd
Si	5	0.585 $\pm$ 0.069cd	0.662 $\pm$ 0.068d
Tm	5	4.071 $\pm$ 0.534b	4.339 $\pm$ 0.071b

Ai: *A. indica*; Ma: *M. azedarach*; Ok: *O. kenyense*; Os: *O. suave*;

Ru: *R. usambarensis*; Si: *S. incanum*; Tm: *T. minuta*;

N: Number of experiment for each plant species;

Vertical means followed by the same letter are not significantly different at  $P \geq 0.05$ ; SE: Standard error.

**Table 25:**

**Overall mean concentrations (w/w) in glucose equivalent at each temperature.**

Temperature	N	% (Mean $\pm$ SE)
Cold	35	1.835 $\pm$ 0.341b
Hot	35	2.167 $\pm$ 0.429a

N: Total number of experiments (7 plants in 5 replicates);  
Means followed by the same letter are not significantly different at  $P \geq 0.05$ ; SE: Standard error.

**(c) Sucrose equivalent**

As in the two previous equivalents (fructose and glucose), sucrose concentrations significantly varied among plant species (Table 26), ( $F = 204.36$ ;  $df = 6$ ;  $P < 0.001$ ) and temperature (Table 27), ( $F = 5.48$ ;  $df = 1$ ;  $P < 0.05$ ).

**Table 26:**

**Mean concentrations (w/w) in sucrose equivalent by plant species for each temperature.**

Plant species	N	% (Mean ± SE)	
		Cold	Hot
Ai	5	0.78 ± 0.0974a	1.10 ± 0.0213a
Ma	5	0.13 ± 0.0034cd	0.13 ± 0.0010cd
Ok	5	0.18 ± 0.0182c	0.15 ± 0.0012c
Os	5	0.005 ± 0.0002d	0.005 ± 0.0007f
Ru	5	0.10 ± 0.0004cd	0.13 ± 0.0070cd
Si	5	0.09 ± 0.0109cd	0.09 ± 0.0019e
Tm	5	0.61 ± 0.0847b	0.65 ± 0.0113b

Ai: *A. indica*; Ma: *M. azedarach*; Ok: *O. kenyense*; Os: *O. suave*;

Ru: *R. usambarensis*; Si: *S. incanum*; Tm: *T. minuta*;

N: Number of experiments for each plant species;

Vertical means followed by the same letter are not significantly different at  $P \geq 0.05$ ; SE: Standard error.

**Table 27:**

**Overall mean concentrations (w/w) in sucrose equivalent for each temperature.**

Temperature	N	% (Mean $\pm$ SE)
Cold	35	0.27 $\pm$ 0.050b
Hot	35	0.32 $\pm$ 0.064a

N: Total number of experiments (7 plants in 5 replicates);  
Means followed by different letters are significantly different at  $P < 0.05$ ;  
SE: Standard error.

**(d) Sugar concentrations (fructose, glucose, sucrose equivalents) in water extracts from fresh plant materials tested by cold anthrone.**

The concentrations in the three equivalents (fructose, glucose, sucrose) encompassing all the test plants whose extracts were treated with cold anthrone are presented in Table 28. The glucose equivalent was the highest (1.84%), as compared to fructose (0.23%) and sucrose (0.27%). For all the equivalents, *A. indica* (0.64% fructose; 5.38% glucose; 0.78% sucrose) and *T. minuta* (0.54% fructose; 4.07% glucose; 0.61% sucrose) had the highest concentrations, while *O. suave* (0.009% fructose; 0.04% glucose; 0.005% sucrose) contained the lowest sugar content (Table 29). There was significant variation among plant species ( $F = 67.83$ ;  $df = 6$ ;  $P < 0.001$ ), sugar equivalents ( $F = 177.36$ ;  $df = 2$ ;  $P < 0.001$ ) and their interactions ( $F = 31.47$ ;  $df = 12$ ;  $P < 0.001$ ). The three equivalents are diversely distributed in different plants as it appears in Appendix 4.



**Table 28:**

**Overall mean concentrations (w/w) in fructose, glucose and sucrose equivalents for all the test plants after test with cold anthrone.**

Sugar equivalent	N	% (Mean $\pm$ SE)
Fructose	35	0.23 $\pm$ 0.042b
Glucose	35	1.84 $\pm$ 0.341a
Sucrose	35	0.27 $\pm$ 0.050b

N: Total number of experiments (7 plants in 5 replicates);  
Means followed by the same letter are not significantly different at  $P \geq 0.05$ ; SE: Standard error.

**Table 29:**

**Mean concentrations (w/w) in fructose, glucose and fructose equivalents among plant species after of test with cold anthrone.**

Plant	N	% (Mean $\pm$ SE)		
		Sugar equivalent		
		Fructose	Glucose	Sucrose
Ai	5	0.64 $\pm$ 0.0780a	5.38 $\pm$ 0.6150a	0.78 $\pm$ 0.0975a
Ma	5	0.10 $\pm$ 0.0026cd	0.84 $\pm$ 0.0211cd	0.13 $\pm$ 0.0033cd
Ok	5	0.16 $\pm$ 0.0028c	1.26 $\pm$ 0.0221c	0.19 $\pm$ 0.0035c
Os	5	0.009 $\pm$ 0.0004d	0.04 $\pm$ 0.0013d	0.005 $\pm$ 0.0002d
Ru	5	0.08 $\pm$ 0.0003cd	0.66 $\pm$ 0.0027cd	0.10 $\pm$ 0.0005cd
Si	5	0.07 $\pm$ 0.0088cd	0.59 $\pm$ 0.0689cd	0.09 $\pm$ 0.0109cd
Tm	5	0.54 $\pm$ 0.0382b	4.07 $\pm$ 0.5346b	0.61 $\pm$ 0.0851b

Ai: *A. indica*; Ma: *M. azedarach*; Ok: *O. kenyense*; Os: *O. suave*;

Ru: *R. usambarensis*; Si: *S. incanum*; Tm: *T. minuta*;

N: Number of experiments for each plant species;

Vertical means followed by the same letter are not significantly different at  $P \geq 0.05$ ; SE: Standard error.

**(e) Sugar concentration (fructose, glucose and sucrose equivalents) in water extracts from fresh plant materials tested by hot anthrone**

As in the cold environment, the concentrations of extracts treated by hot anthrone (Tables 30 and 31) show a high degree of variation among sugar equivalents in the pooled test plants ( $F = 6504.11$ ;  $df = 2$ ;  $P < 0.001$ ) and among individual plants for each equivalent ( $F = 3136.45$ ;  $df = 6$ ;  $P < 0.001$ ). Glucose equivalent had the highest concentration (2.16%), and the difference between fructose and sucrose equivalents was significant. At the individual plant level *A. indica* remained the richest for all equivalents (0.89% fructose; 7.40% glucose; 1.10% sucrose), followed by *T. minuta* (0.52% fructose; 4.34% glucose; 0.65% sucrose) while *O. suave* (0.005% fructose; 0.04% glucose; 0.005% sucrose) showed the poorest sugar content. There is a highly significant influence by the interaction between sugar equivalents and individual plant species ( $F = 1457.77$ ;  $df = 12$ ;  $P < 0.001$ ). The difference in concentration of the three equivalents due to the difference in plant species is presented in Table 31 and Appendix 7.

**Table 30:**

**Overall mean concentrations (w/w) in fructose, glucose and sucrose equivalents in all the test plants after test with hot anthrone.**

	N	% (Mean $\pm$ SE)
Sugar equivalent		
Fructose	35	0.26 $\pm$ 0.05c
Glucose	35	2.16 $\pm$ 0.43a
Sucrose	35	0.32 $\pm$ 0.06b

N: Total number of experiments (7 plants in 5 replicates);  
Means followed by different letters are significantly different at  $P < 0.05$ ;  
SE: Standard error.

**Table 31:**

**Mean concentrations (w/w) in fructose, glucose and sucrose equivalents of individual plant species after test with hot anthrone.**

Plant	N	% (Mean ± SE)		
		Sugar equivalent		
		Fructose	Glucose	Sucrose
Ai	5	0.89 ± 0.0157a	7.40 ± 0.1341a	1.10 ± 0.0212a
Ma	5	0.10 ± 0.0007cd	0.87 ± 0.0061cd	0.13 ± 0.0010cd
Ok	5	0.12 ± 0.0009c	1.02 ± 0.0074c	0.15 ± 0.0011c
Os	5	0.005 ± 0.0005f	0.04 ± 0.0045f	0.005 ± 0.0007f
Ru	5	0.10 ± 0.0053cd	0.84 ± 0.0441d	0.13 ± 0.0070cd
Si	5	0.07 ± 0.0014e	0.60 ± 0.0122e	0.09 ± 0.0019e
Tm	5	0.52 ± 0.0084b	4.34 ± 0.0714b	0.65 ± 0.0112b

Ai: *A. indica*; Ma: *M. azedarach*; Ok: *O. kenyense*; Os: *O. suave*;

Ru: *R. usambarensis*; Si: *S. incanum*; Tm: *T. minuta*;

N: Number of experiments for each plant species;

Vertical means followed by the same letter are not significantly different at  $P \geq 0.05$ ; SE: Standard error.

#### 4.2.2.2 Sugar concentration in extracts from the water phase of sequential extraction

In the water-phase extracts of the sequential extraction, the overall concentrations by equivalent were once more dominated by glucose with 22.27% while fructose and sucrose were almost equal with 7.05 and 7.62%, respectively (Table 32). At the individual plant level, concentrations were very variable with *O. kenyense* (10.95% fructose; 38.85 glucose; 12.87% sucrose) and *M. azedarach* (8.94% fructose; 30.24% glucose; 10.13% sucrose) yielding the highest values for all the equivalents (Table 33). *O. suave* always showed the lowest sugar content with 3.45% for fructose, 6.67% for glucose and 2.63% for sucrose.

As in the extracts from fresh plant materials, the concentration was significantly different according to (i) the plant species ( $F = 129.97$ ;  $df = 6$ ;  $P < 0.001$ ), (ii) the sugar equivalent ( $F = 640.77$ ;  $df = 2$ ;  $P < 0.001$ ), and (iii) their interaction ( $F = 28.73$ ;  $df = 12$ ;  $P < 0.001$ ). The variation by plant for each sugar equivalent is presented in Table 33; Appendix 8.

**Table 32:**

**Overall mean concentrations (w/w) by each sugar equivalent in all the test plants after sequential extraction and test with hot anthrone.**

Sugar equivalent	N	% (Mean $\pm$ SE)
Fructose	35	7.05 $\pm$ 0.44b
Glucose	35	22.27 $\pm$ 1.89a
Sucrose	35	7.62 $\pm$ 0.60b

N: Total number of experiments (7 plants in 5 replicates);  
Means followed by the same letter are not significantly different at  $P \geq 0.05$ ;  
SE: Standard error.

**Table 33:**

**Mean concentrations (w/w) of each sugar equivalent in each plant species after sequential extraction and test with hot anthrone.**

Plant	N	% (Mean ± SE)		
		Sugar equivalent		
		Fructose	Glucose	Sucrose
Ai	5	4.44 ± 0.32e	10.31 ± 1.83e	3.93 ± 0.43e
Ma	5	8.94 ± 0.29b	30.24 ± 1.26b	10.13 ± 0.40b
Ok	5	10.95 ± 0.35a	38.85 ± 1.51a	12.87 ± 0.48a
Os	5	3.45 ± 0.10f	6.67 ± 0.43e	2.63 ± 0.14f
Ru	5	5.43 ± 0.30d	16.89 ± 1.89d	5.89 ± 0.60d
Si	5	7.78 ± 0.41c	25.23 ± 1.77c	8.54 ± 0.56c
Tm	5	8.36 ± 0.23bc	27.73 ± 1.00bc	9.33 ± 0.32bc

Ai: *A. indica*; Ma: *M. azedarach*; Ok: *O. kenyense*; Os: *O. suave*;

Ru: *R. usambarensis*; Si: *S. incanum*; Tm: *T. minuta*;

N: Number of experiment for each plant species;

Vertical means followed by the same letter are not significantly different at

$P \geq 0.05$ ; : Standard error.



#### 4.2.2.3 Discussion

The three sugars (fructose, glucose and sucrose) were chosen as standards because they are among the most important in the composition of the natural food of the phytophagous insects, including sandflies. Their most common potential sources are floral nectar, extrafloral nectar, honeydew, pollen and phloem sap. They are found in the free state along with, or as constituents of some oligosaccharides such as sucrose, fructomaltose, trehalose and melezitose (Auclair, 1963, Hagen *et al.*, 1984, Kevan and Baker, 1984 Schlein and Warburg, 1986, Killick-Kendrick and Killick-Kendrick, 1987). The same sugars have been detected in the gut of wild-caught sandflies using TLC (Thin Layer Chromatography) (Lewis and Domoney, 1966), in *P. ariasi* wild-caught or laboratory-fed (after starvation) on plant infested by honeydew producing aphids and coccids using HPLC (High Performance Liquid Chromatography) and GC (Gas Chromatography) (Moore *et al.*, 1987) and in wild-caught *P. p. perfiliewi* and *P. perniciosus* from different Italian localities using HPLC (MacVicker *et al.*, 1990).

The test with cold and hot anthrone was adopted because it had been established that cold anthrone test read within 60 minutes was specific for fructose and other sugars with fructose moiety whereas a longer duration or temperature could yield positive reactions with other sugars (Van Handel, 1972; Young *et al.*, 1980); in other

circumstances hot anthrone has proved an efficient method for estimating sugar content in crop plants (Yoshida, 1976).

Optical densities from fructose and sucrose standards were not significantly affected by the temperature while glucose standard was much more responding to hot than to cold anthrone; however, its higher value was inferior to the lower value of fructose or sucrose under either temperature, which confirms the high specificity of anthrone test for fructose.

Extracts from fresh plants presented a very wide variation of responses to anthrone test under both temperatures. Thus, a preliminary test was adopted to determine for each plant an optimum volume detectable by the test or fitting within the range of standard sugars; the working volumes varied between 0.1 ml with the most responding plant (*A. indica*) and 5.0 ml with the less responding *O. suave*. Extracts from sequential extraction were also variable in their response to spectrophotometry after treatment with hot anthrone but with a more moderate sensitivity and within a more accommodating range with reference to the standard sugars. This made it possible to use the same volume of 0.1 ml for all the test plants.

The different optimum volumes needed for spectrophotometrical sensitivity and the different optical densities recorded reflect the sugar content in different plants at least as long as the anthrone test is concerned. Also, a positive correlation was found between optical density and sugar

concentration for each sugar standard and for each individual plant (R = 0.999; P < 0.001).

In fresh extracts, plants with lower optimum volume (e.g. *A. indica* and *T. minuta*) showed a higher sugar concentration while those requiring higher volumes (e.g. *O. suave*) had a lower sugar concentration.

In general, more sugar was extracted at hot temperature than at cold temperature; but at individual plant level the effect could (in rare cases) be in favour of cold temperature (e.g. *O. kenyense* and *O. suave* with glucose equivalent).

Under cold and hot conditions and with the two modes of extractions, glucose equivalent was the most important, with fructose and sucrose concentrations being almost similar in most of the tests. The relative distribution of the three equivalents in all the test plants in the present study is comparable with the proportions found by MacVicker *et al.* (1990) in wild *P. p. perfiliawi* from different localities of Italy in which HPLC determined glucose (31.71%), fructose (20.04%) and sucrose (21.28%) among other sugar constituents, including melezitose, maltose, trehalose and turanose.

There were particular instances like in cold anthrone test where *O. suave* showing more fructose than sucrose while *R. usambarensis* recorded more sucrose than fructose; also in the test on the extracts from fresh plants with hot anthrone, sucrose could become more important than fructose.

In comparing the two modes of extraction the immediate observation is that sequential extraction yields more sugar for each plant and each equivalent. This might be due to the fact that all the extraction procedures involved in sequential extraction comprising rotary evaporation, dry-freezing and repeated hot extractions with alcohol were meant to concentrate sugars. However, another important observation is that fresh extracts were dominated by *A. indica* and *T. minuta* while in sequential extraction *O. kenyense* and *M. azedarach* produced higher sugar concentrations. On the other hand, sugars extracted from fresh plant materials would seem to reflect most likely the available and mobile sugars of the phloem sap (Auclair, 1963).

The main objective of this investigation was to find out whether and at what extent the discrepancy of feeding rates recorded on different plant may be a consequence of the difference in sugar content of the test plants, but a correlation test performed at that effect did not show any significant correlation between the two variables ( $R = -0.2721$ ;  $P = 0.1138$ ) apart from *M. azedarach* for which a slight correlation was observed ( $R = 0.9025$ ;  $P = 0.0360$ ).

Interestingly, the concentration of sucrose in *R. usambarensis* (5.89%) and *M. azedarach* (10.13%) obtained through sequential extraction is in the range of the concentrations found by Auclair (1963) in the sap of different species of *Salix* and *Picea* (4-10%); which is consistent with the 10% sucrose, frequently used for feeding sandflies in laboratory experiments, like in the present study. The diverse distribution of fructose,

glucose and sucrose in the test plants is consistent with the findings by Kevan and Parker (1984) that these sugars occurred in different proportions according to different plant families.

Noteworthy, *R. usambarensis* and *M. azedarach* which gave moderate sugar concentration elicited the highest feeding response while *A. indica*, *O. kenyense* and *T. minuta* with the highest sugar concentration were associated with very moderate to poorest feeding rate. With amino acid in aphid nutrition, Auclair (1963) demonstrated that beyond a given concentration, the nutrients could have a deterrent effect.

### 4.3 Behavioural responses by *P. duboscqi* to olfactory stimuli from *M. azedarach*, *O. suave*, *R. usambarensis* and *T. minuta*

#### 4.3.1. Plants tested against control

The result of the bioassay, where each single plant was tested against a control (Table 34), has produced two groups : (a) repellents characterised by a positive result of the operation using the formula  $(C-T)/(C+T) \times 100$  (where C = number of flies counted in the control area; T = number of flies counted in the treatment area and C + T = total number of responding insects) and (b) attractants when the result turns out to be negative (Table 36). Thus, *O. suave* and *T. minuta* were repellents, whereas *M. azedarach* and *R. usambarensis* were attractants.

#### 4.3.2. Plant versus plant bioassay

After the attractancy/repellency character of each of the test plants was established through a test against control, the next step was to estimate the differential response (preference) by opposing the different plants by pair (repellent versus repellent; repellent versus attractant, attractant versus attractant). From the results in Tables 34 and 35, not only did the differential response vary with reference to control ( $F = 130.02$ ;  $df = 3$ ;  $P < 0.001$ ) but also, there was significant difference between the test plants irrespective of their categories ( $F = 121.45$ ;  $df = 4$ ;  $P < 0.001$ ).

Table 36 gives the percentage responses with respect to the exposure time from 5 to 720 min. In most cases, the effect of the exposure

time was not significant especially in repellent groups. The only significant variation observed was in the attractant group: with time, *M. azedarach* apparently changed from attractancy to repellency (Table 36, Fig. 9a-b). However, generally, the difference in behavioural response was more significantly affected by the test plant ( $F = 131.59$ ;  $df = 5$ ;  $P < 0.001$ ) than by the exposure duration ( $F = 1.05$ ;  $df = 9$ ;  $P > 0.05$ ).

**Table 34:**

**Differential responses by *P. duboscqi* to olfactory stimuli from different plant species with an artificial plant as a control.**

Control versus test plant	N	% (Mean $\pm$ SE)
Control vs <i>T. minuta</i>	50	44.796 $\pm$ 3.92a
Control vs <i>O. suave</i>	50	43.049 $\pm$ 2.11a
Control vs <i>M. azedarach</i> <sub>1</sub> )	50	-11.489 $\pm$ 2.59cd
Control vs <i>M. azedarach</i> <sub>2</sub>	50	-4.693 $\pm$ 1.45bc
Control vs <i>R. usambarensis</i> <sub>1</sub>	50	-10.0 $\pm$ 1.51cd
Control vs <i>R. usambarensis</i> <sub>2</sub>	50	-14.0.49 $\pm$ 3.01d

Vs: Versus; N: Number of experiments by test; 1: Daytime; 2: Overnight  
Means followed by the same letter are not significantly different at  
 $P \geq 0.05$ ; SE: Standard error.



**Table 35:**

**Behavioural responses by *P. duboscqi* to olfactory stimuli from different plant species tested one against another.**

Couple number	Plant couple	N	% (Mean $\pm$ SE)
1	<i>M. azedarach</i> vs <i>T.minuta</i>	50	79.11 $\pm$ 0.90a 7.96 $\pm$ 0.65b
2	<i>R. usambarensis</i> vs <i>O.suave</i>	50	55.11 $\pm$ 1.84a 13.22 $\pm$ 0.99b
3	<i>T. minuta</i> vs <i>O.suave</i>	50	34.67 $\pm$ 2.35b 42.93 $\pm$ 2.07a
4	<i>R. usambarensis</i> vs <i>M.azedarach</i>	50	35.96 $\pm$ 0.74b 48.34 $\pm$ 0.90a

VS: Versus; N: Number of experiments by test;  
Paired means followed by different letters are significantly different at  
P < 0.05; SE: Standard error.

**Table 36:**  
**Differential responses by *P. duboscqi* to olfactory stimuli from different plant species tested against a control with increasing exposure duration.**

Time (min)	N	% (Mean ± SE)							
		Test plant							
		Ma <sub>1</sub>	Ma <sub>2</sub>	Os	Ru <sub>1</sub>	Ru <sub>2</sub>	Tm		
5	50	-17.49 ± 0.73bc	-9.74 ± 0.92a	32.95 ± 3.15a	-15.74 ± 1.80b	-16.77 ± 2.13b	44.95 ± 1.71a		
10	50	-19.43 ± 1.54bc	-9.86 ± 1.21a	45.61 ± 2.02a	-14.97 ± 1.70ab	-12.44 ± 2.02b	50.95 ± 1.60a		
15	50	-17.24 ± 0.94bc	-7.08 ± 1.74a	45.60 ± 2.31a	-15.35 ± 1.81ab	-15.41 ± 2.77b	54.95 ± 1.40a		
30	50	-18.65 ± 1.78c	-1.99 ± 1.11a	47.30 ± 1.99a	-8.48 ± 1.00ab	-24.73 ± 2.70b	50.86 ± 1.07a		
45	50	-20.59 ± 2.73c	-4.37 ± 1.03a	40.09 ± 2.47a	-13.13 ± 1.65ab	-19.73 ± 2.77b	46.61 ± 1.73a		
60	50	-17.83 ± 2.38bc	-7.32 ± 1.78a	38.38 ± 2.25a	-10.13 ± 2.33ab	-16.00 ± 2.23b	36.84 ± 1.78a		
120	50	-9.05 ± 2.92bc	-5.71 ± 1.34a	45.45 ± 2.75a	-6.70 ± 1.35ab	-11.81 ± 2.60b	44.04 ± 2.23a		
180	50	-11.63 ± 2.43bc	1.43 ± 1.60a	44.63 ± 1.34a	-10.46 ± 0.84ab	-19.39 ± 1.71b	42.36 ± 2.42a		
360	50	2.56 ± 43ab	-0.69 ± 2.76a	42.67 ± 1.78a	-4.14 ± 0.56ab	-18.63 ± 3.58b	39.90 ± 2.44a		
720	50	14.46 ± 2.28a	1.21 ± 1.15a	47.90 ± 1.69a	-1.49 ± 0.93a	15.53 ± 4.94a	38.50 ± 1.98a		

Ma<sub>1</sub>: *M. azedarach* tested daytime; Ma<sub>2</sub>: *M. azedarach* tested overnight; Os: *O. suave*;  
 Ru<sub>1</sub>: *R. usambarensis* tested daytime; Ru<sub>2</sub>: *R. usambarensis* tested overnight; Tm: *T. minuta*;  
 N: Number of tests : Min: Minutes; Column means followed by the same letter are not significantly different at P ≥ 0.05; SE: Standard error.

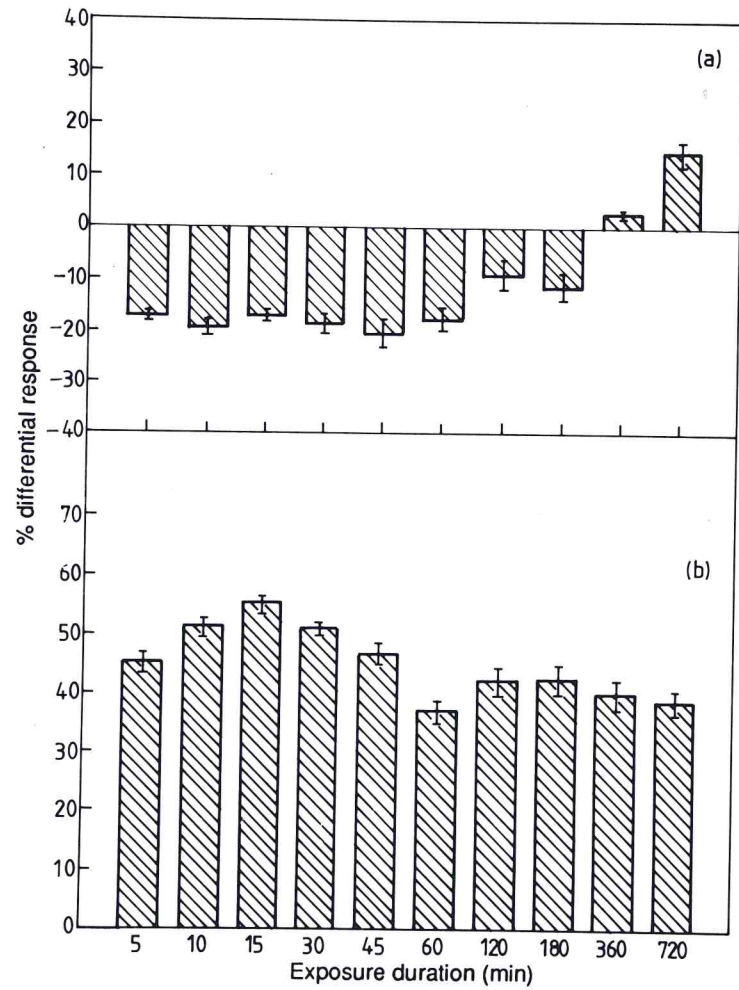

**Figure 9a-b:** Differential responses by *P. duboscqi* to olfactory stimuli from *M. azedarach* (a) and *T. minuta* (b) tested against an artificial plant as a control, through an increasing exposure duration.

#### 4.3.3 Discussion

*R. usambarensis* and *M. azedarach*, which had the highest feeding rate attracted more *P. duboscqi* than did the control while *O. suave* and *T. minuta* attracted less than did the control, suggesting that plants of the first group behaved as attractants and those of the second group behaved as repellents. In tests where one member of the first group was checked against one member of the second group, members of the first group attracted much more flies than did those of the second group. Comparing members within the same group showed that *M. azedarach* was a more attractant than *R. usambarensis* and *T. minuta* was more of a repellent than *O. suave*.

The attempt to evaluate the effect of the photoperiod on the two attractant plants revealed that *M. azedarach* attracted more flies during the day while *R. usambarensis* was more preferred during the night. The first case was consistent with the observations reported by Metcalf and Metcalf (1992) according to which kairomones were more active during sunny and hot days than during cool and overcast days or at night; the second case came to support the findings by Schlein *et al.* (1986) in which *P. papatasi* fed much more on *C. spinosa* overnight than it did during daytime. Apart from *M. azedarach* in daytime tests and the two extremes (5 and 720 min) of *R. usambarensis*, the exposure duration did not affect significantly the outcome of the tests.

In that context it has even been reported (Finch, 1986) that insects respond to odours within milliseconds rather than minutes.

The correlation test revealed a general positive relationship between feeding rate and olfactory stimuli ( $R = 0.8230$ ,  $P < 0.001$ ). At individual plant level, the correlation could be either positive or indifferent.

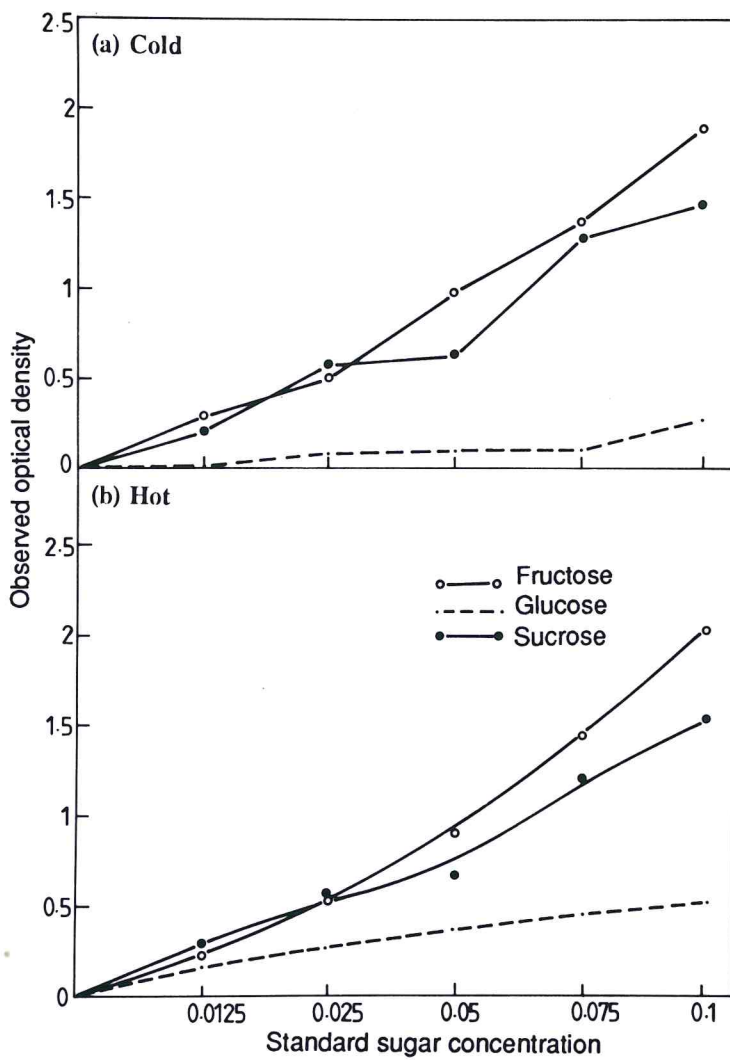

**Figure 7a-b:** Curves drawn by plotting observed optical densities (spectrophotometry at 630 nm) against the corresponding concentrations of the standard sugars tested with cold (a) and hot (b) anthrone.

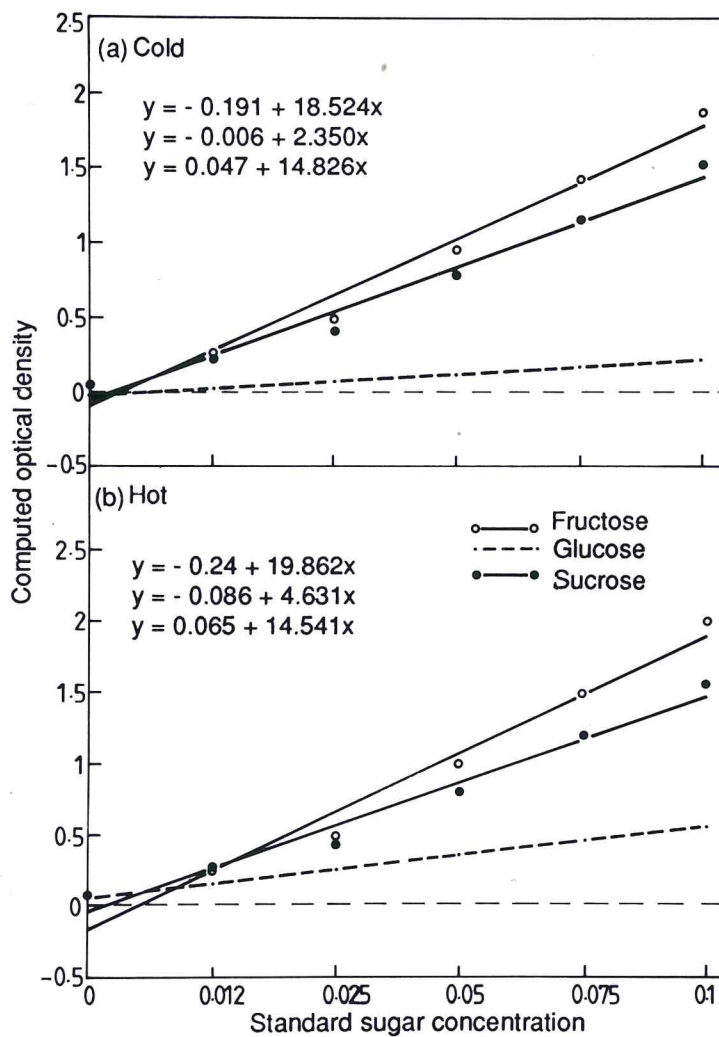

**Figure 8a-b:** Regression lines drawn from computed optical densities plotted against the corresponding concentrations of standard sugars tested with cold (a) and hot (b) anthrone.

#### 4.4 Effects of plant diets on sandfly biology

##### 4.4.1 Fecundity, life cycle, developmental survival and reproductivity

##### 4.4.1.1 *S. ingrami*

##### (a) Fecundity

Table 37 presents, for each diet, the total number of flies laying, the total and mean numbers of eggs per fly. The highest rate was recorded from the females maintained on *R. usambarensis* (89.90 eggs/female) and the lowest from those given *S. incanum* (79.20 eggs/female). The maxima were 163, 160, 161 and 137 eggs in females given *R. usambarensis*, *S. incanum*, sucrose and water, respectively. Diets significantly affected fecundity ( $F = 4.77$ ;  $df = 3$ ;  $P < 0.05$ ).



**Table 37:**

**Fecundity of *S. ingrami* females maintained on different diets during the pre-oviposition period.**

Diet	Number of flies laying	Number of eggs	Mean $\pm$ SE
Ru	100	8990	89.90 $\pm$ 3.14a
Si	90	7128	79.20 $\pm$ 3.52b
Su	108	9584	88.78 $\pm$ 3.00a
Wa	106	8746	82.51 $\pm$ 2.66ab

Ru: *R. usambarensis*; Si: *S. incanum*; Su: Sucrose; Wa: Water;  
Means followed by the same letter are not significantly different at  $P \geq 0.05$ ;  
SE: Standard error.

**(b) Developmental duration**

**(i) Duration of the larval and pupal stages**

In Table 38, the developmental duration was expressed in average number of days from one instar to the next. Within the larval stage, the first instar (3 days) and the fourth instar (5-6 days) were longer than intermediate instars while the pupal stage (8 days) was longer than any individual instar of the larval stage. The first instar (3 days). Within instar and stages there was no significant difference due to the diets (Appendix 9).

**(ii) Duration of the main developmental periods of the life cycle**

In addition to the duration of individual instars and stages, some important phenological periods comprising more than one instar/stage have been considered, making it possible to forecast how long the next stage of the life cycle would be expected, counting from the day of blood meal (Table 39). For instance, from the time the females have taken the blood meal, the oviposition would take place in approximately 5,5 days, hatching in 11 days, pupation in 16 days and emergence adults in 35 days. Within any of the successive stages there was no significant difference in the life cycle duration due to the diets (Appendix 10).

Table 38:

Developmental duration (days) of larval and pupal stages when *S. ingrami* females were maintained on different diets during the pre-oviposition period.

Diet	Mean $\pm$ SE				
	Stage/instar				
	Instar <sub>1</sub>	Instar <sub>2</sub>	Instar <sub>3</sub>	Instar <sub>4</sub>	Pupa
Ru	3.90 $\pm$ 0.23a	2.26 $\pm$ 0.14a	2.92 $\pm$ 0.22a	5.56 $\pm$ 0.41a	8.40 $\pm$ 0.66a
Si	3.90 $\pm$ 0.29a	2.38 $\pm$ 0.18a	3.00 $\pm$ 0.22a	6.24 $\pm$ 0.67a	8.12 $\pm$ 0.70a
Su	3.96 $\pm$ 0.29a	2.40 $\pm$ 0.10a	2.84 $\pm$ 0.26a	6.40 $\pm$ 0.56a	8.40 $\pm$ 0.57a
Wa	4.10 $\pm$ 0.40a	2.46 $\pm$ 0.16a	3.16 $\pm$ 0.32a	6.30 $\pm$ 0.28a	8.26 $\pm$ 0.55a

Ru: *R. usambarensis*; Si: *S. incanum*; Su: Sucrose; Wa: Water;  
 Column means followed by the same letter are not significantly different at  $p \geq 0.05$ ; SE: Standard error.

Table 39:

Duration (days) of the main developmental stages/periods of the life cycle of *S. ingrami*, when females were maintained on different diets during the pre-oviposition period.

Diet	Mean ± SE						
	Developmental stage/period						
	Oogenesis	Embryonation	Larval stage	Pupal stage	Embry-Emerg	Oogen-Emerg	
Ru	5.40 ± 0.35a	5.56 ± 0.31a	15.42 ± 0.95a	8.40 ± 0.66a	29.16 ± 1.75a	35.14 ± 0.81a	
Si	5.18 ± 0.32a	5.62 ± 0.30a	15.50 ± 1.22a	8.12 ± 0.70a	29.30 ± 2.08a	34.30 ± 1.70a	
Su	5.62 ± 0.29a	5.32 ± 0.21a	15.60 ± 1.11a	8.40 ± 0.57a	29.30 ± 1.70a	34.72 ± 1.60a	
Wa	5.54 ± 0.39a	5.58 ± 0.22a	15.98 ± 0.86a	8.26 ± 0.66a	29.90 ± 1.58a	35.22 ± 1.10a	

Ru: *R. usambarensis*; Si: *S. incanum*; Su: Sucrose; Wa: Water;  
 Oogen: Oogenesis; Embry: Embryonation; Emerg: Emergence;  
 Vertical means followed by the same letter are significantly different at  $P \geq 0.05$ ; SE: Standard error.

**c. Developmental survival, reproductivity and sex-ratio**

The developmental survival through different stages (oogenesis-oviposition-hatching-pupation-mergence), is presented in Table 40 in terms of number of individuals from a stage/instar to another and as a percentage ratio of a given stage over the immediate former or another appropriate one according to the parameter in question. The developmental survival with reference to eggs is presented in Fig. 10 and appendix 11.

Reproductivity (Table 41) is understood as a result or an end-point of the developmental survival. The total reproductivity is expressed by the total number of adults in the progeny over the total number of females completing a successful oogenesis in the batch. What is referred to as effective reproductivity is expressed by the number of females in the progeny produced by one female in the parental reproductive batch.

For example, with sucrose, from 123 females having taken a blood meal, 108 (87.80% survival) laid eggs 9584 which gave 6104 larvae (63.69% survival), these developed to 4853 pupae (79.51% survival) from which emerged 3274 adults (67.46% survival) which divided by the number of females laying eggs gave 30.31 adults per female (total reproductive rate) comprising 16.09 F1 females per parental female (effective reproductive rate). All along the developmental stage, there was no significant difference survival rates, but there was a significant difference in reproductivity and sex ration associated with diets (Appendix 12).

**Table 40:**  
**Survival of females and developmental stages of the progeny in *S. ingrami* when the former were maintained on different diets during the pre-oviposition period.**

Diet	Numbers and survival rate {% (Mean ± SE)}										
	Fed	OR	Laying	Eggs	HR	Larva	Larva-Pupa	Pupa	EmR	Adult	
Ru	110	90.91 ± 4.66a ()	100	8990	63.24 ± 5.39a	5685	83.46 ± 3.13a	4745	71.92 ± 3.91a	3413	
Si	115	78.26 ± 3.72a	90	7128	57.87 ± 3.76a	4125	79.39 ± 3.54a	3275	70.05 ± 5.02a	2292	
Su	123	87.80 ± 5.36a	108	9584	63.69 ± 3.88a	6104	79.51 ± 2.84a	4853	67.46 ± 5.38a	3274	
Wa	126	84.13 ± 1.90a	106	8746	57.76 ± 4.89a	5052	75.85 ± 3.64a	3832	71.24 ± 5.52a	2730	

Ru: *R. usambarensis*; Si: *S. incanum*; Su: Sucrose; Wa: Water; OR: Oviposition rate; HR: Hatching rate; EmR: Emergence rate; () : Percentages are referred to the number of the immediately preceding one; Vertical means followed by the same letter are not significantly different at P ≥ 0.05; S: Standard error.

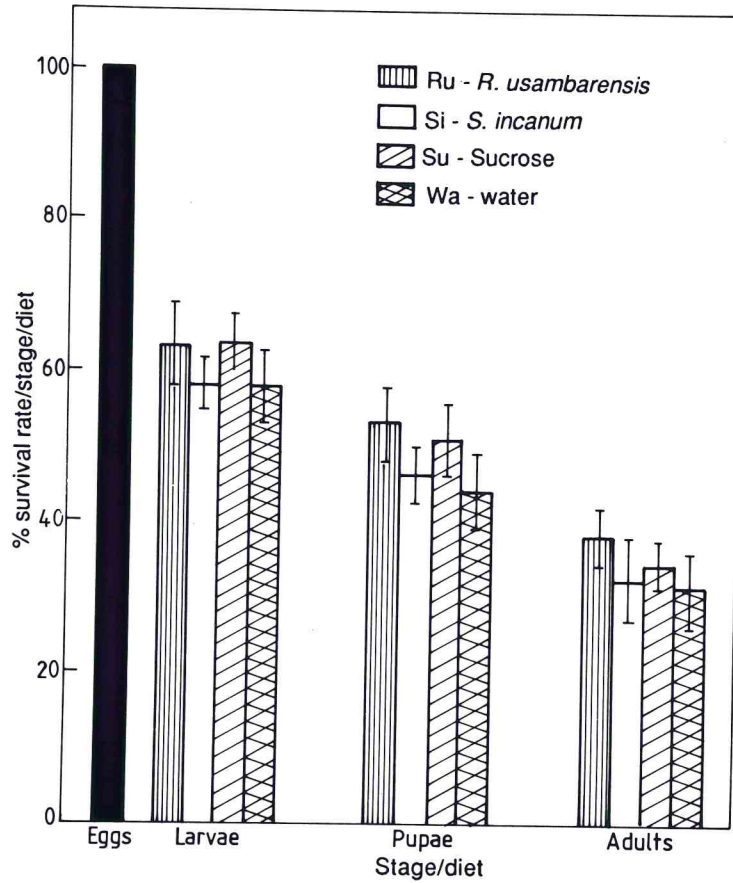

Figure 10: % survival of developmental stages of the progeny, with reference to eggs, when *S. ingrami* females were maintained on different diets during the pre-oviposition period.

**Table 41:**  
**Reproductivity of *S. ingrami* females and sex-ratio in the progeny when the former were maintained on different diets during the pre-oviposition period.**

Diet	Number, reproductive rate and sex-ratio (Mean ± SE)									
	Status/rate									
	Laying	TR	Adults	Females	Males	SR	ER			
Ru	100	34.13 ± 3.16a	3413	1712	1701	0.51 ± 0.49a	17.12 ± 2.35a			
Si	90	25.47 ± 2.87b	2292	1124	1168	0.49 ± 0.51a	12.98 ± 1.45b			
Su	108	30.31 ± 3.16a	3274	1738	1536	0.53 ± 0.47a	16.06 ± 2.04a			
Wa	106	25.75 ± 1.49b	2730	1402	1328	0.51 ± 0.49a	13.22 ± 1.21ab			

Ru: *R. usambarensis*; Si: *S. incanum*; TR: Total reproductive rate; SR: Sex-ratio; ER: Effective reproductive rate; Vertical means followed by the same letter are not significantly different at  $P \geq 0.05$ ; SE: Standard error.



4.4.1.2. *P. duboscqi*

(a) Fecundity

Data recorded in Table 42 shows that the highest mean number of eggs per female was observed in the flies maintained on *R. usambarensis* (54.03) and the lowest in those flies given water (46.82) while *S. incanum* (49.92) and sucrose (51.82) produced an intermediate fecundity category. The maxima recorded were 101, 85, 127 and 85 eggs with flies maintained on *R. usambarensis*, *S. incanum*, sucrose and water respectively. The results show a significant difference ( $F = 2.66$ ;  $df = 3$ ;  $P < 0.05$ ) in fecundity in relation with the difference in diet.

**Table 42:**

**Fecundity of *P. duboscqi* females maintained on different diets during the pre-oviposition period.**

Diet	Number of flies	Number of eggs	Mean $\pm$ SE
Ru	108	5835	54.03 $\pm$ 1.89a
Si	106	5291	49.92 $\pm$ 1.63ab
Su	115	5959	51.82 $\pm$ 1.93ab
Wa	109	5103	46.82 $\pm$ 1.70b

Ru: *R. usambarensis*; Si: *S. incanum*; Su: Sucrose; Wa: water;

Means followed by the same letter are not significantly different at  $P \geq 0.05$ ;

SE: Standard error.

**b. Developmental duration**

**(i) Developmental duration of larval and pupal stages**

The mean durations varied between 4.5 and 5.5 days for instar<sub>1</sub>, between 2.7 and 3.7 for instar<sub>2</sub>, between 3.3 and 4.5 for instar<sub>3</sub>, between 7.5 and 9.0 for instar<sub>4</sub> and 8.0 and 10.0 for the pupal stage. As in *S.ingrami*, the first and fourth instars were longer than the intermediate ones and the pupal stage was longer than any individual larval stage. Here also, there was no difference in relation with the diets (Table 43, Appendix 13).

**(ii) Duration of the main developmental periods of the life cycle**

The results presented in Table 44 provide an overview of the main periods making up the life cycle and the effect of the different diets on their duration. Among these periods comprising oogenesis, embryonation, larval stage, pupal stage, embryonation-emergence, oogenesis-emergence, oogenesis took longer in flies maintained on sucrose (8.24 days) or water (7.38 days) than those given *R. usambarensis* (6.78 days) or *S. incanum* (6.90 days). For the other periods, there was no significant difference in duration (Appendix 14) accountable for by diets.

Table 43:

Developmental duration (days) of larval instars and pupal stage when *P. duboscqi* females were maintained on different diets during the pre-oviposition period.

Diet	Mean ± SE				
	Instar/stage				
	Instar <sub>1</sub>	Instar <sub>2</sub>	Instar <sub>3</sub>	Instar <sub>4</sub>	Pupa
Ru	4.84 ± 0.20a	2.96 ± 0.10a	3.60 ± 0.29a	8.52 ± 0.42a	8.66 ± 0.22a
Si	4.80 ± 0.22a	3.36 ± 0.17a	3.90 ± 0.15a	8.12 ± 0.36a	9.60 ± 0.41a
Su	4.48 ± 0.24a	3.18 ± 0.23a	4.04 ± 0.43a	7.80 ± 0.42a	8.60 ± 0.31a
Wa	5.30 ± 0.15a	3.38 ± 0.20a	3.80 ± 0.09a	8.58 ± 0.04	8.96 ± 0.54a

Ru: *R. usambarensis*; Si: *S. incanum*; Su; Sucrose; Wa: Water;  
 Vertical means followed by the same letter are not significantly different at  $P \geq 0.05$ ; SE: Standard error.

Table 44:

Duration (days) of the main stages/periods in the life cycle when *P. duboscqii* females were maintained on different diets during the pre-oviposition period.

Diet	Mean ± SE						
	Stage/period						
	Oogenesis	Embryonation	Larval stage	Pupal stage	Embry-Emerg	Oogen-Emerg	
Ru	6.78 ± 0.24b	6.50 ± 0.16a	20.00 ± 0.56a	8.66 ± 0.22a	34.96 ± 0.42a	41.66 ± 0.44a	
Si	6.90 ± 0.17b	6.44 ± 1.50a	21.78 ± 1.83a	9.60 ± 0.41a	36.42 ± 0.67a	43.12 ± 0.55a	
Su	8.24 ± 0.48a	5.44 ± 0.11a	19.68 ± 1.08a	8.60 ± 0.31a	34.66 ± 1.24a	42.96 ± 1.17a	
Wa	7.38 ± 0.44a	6.56 ± 0.10a	21.06 ± 0.27a	8.96 ± 0.52a	36.58 ± 0.68a	43.96 ± 0.55a	

Ru: *R. usambarensis*; Si: *S. incanum*; Su: Sucrose; Wa: Water; Embry: Embryonation; Oogen: Oogenesis; Emerg: Emergence; Vertical means followed by the same letter are not significantly different at  $P \geq 0.05$ ; SE: Standard error.

**c. Developmental survival**

**(i) Developmental survival during the larval stage**

The developmental survival within the larval stage is expressed as a percentage of numbers of the larvae moulting from one instar to the next through the pupal stage. Table 45 presents the survival rate, for each instar and each diet on which the parental females had been maintained during the pre-oviposition period. From the results there is no significant difference within any given stage due to the difference in diets (Table 45; Appendix 15).

**(ii) Developmental survival from parental females to the emergence of adults in the progeny**

Table 46 presents, for each diet, the numbers and survival rates from the females laying eggs to the emergence of adults in the progeny. The different diets did not show any significant effect on the survival within the successive stages of the life cycle (Table 46, Appendix 16). The developmental survival of the main stages with reference to the eggs is presented in Fig.11; Appendix 17).

**Table 45:**  
**Developmental survival during the larval stage of the progeny in *P. duboscqi* when females were maintained on different diets during the pre-oviposition period.**

Diet	Number and survival rate {% (Mean ± SE)}											
	Instar/stage											
	Instar <sub>1</sub>		Instar <sub>2</sub>		Instar <sub>3</sub>		Instar <sub>4</sub>		Instar <sub>4</sub>		Pupa	
Ru	3362	94.17 ± 0.008a	3155	94.41 ± 0.015a	2966	95.16 ± 0.005a	2816	89.41 ± 0.053a	2512			
Si	3041	91.55 ± 0.032a	2821	93.43 ± 0.031a	2671	93.22 ± 0.019a	2511	89.28 ± 0.033a	2284			
Su	3281	94.54 ± 0.014a	3117	95.84 ± 0.010a	2982	94.91 ± 0.008a	2815	83.07 ± 0.043a	2272			
Wa	2969	93.66 ± 0.011a	2788	94.07 ± 0.014a	2600	91.50 ± 0.013a	2363	83.80 ± 0.036a	2013			

Ru: *R. usambarensis*; Si: *S. incanum*; Su: Sucrose; Wa: Water;  
 Vertical means followed by the same letter are not significantly different at  $P \geq 0.05$ ; SE: Standard error.

Table 46:

Survival of females and developmental stages of the progeny in *P. duboscqi* when the former were maintained on different diets during the pre-oviposition period.

Diet	Number and survival rate { % (Mean ± SE) }										
	Status/stage										
	Fed	OR	Laying	Egg	HR	Larva	Larva-Pupa	Pupa	EmR	Adults	
Ru	112	96.43 ± 2.91a	108	5835	57.18 ± 3.38a	3362	74.72 ± 3.05a	2512	86.82 ± 2.70a	2151	
Si	125	84.80 ± 6.07a()	106	5291	57.49 ± 3.80a	3041	75.11 ± 6.50a	2284	85.95 ± 7.96a	1737	
Su	120	95.83 ± 2.64a	115	5959	53.71 ± 6.92a	3281	69.25 ± 2.90a	2272	73.25 ± 4.38a	1631	
Wa	121	90.08 ± 2.94a	109	5103	56.53 ± 5.63a	2969	67.80 ± 5.07a	2013	76.12 ± 6.94a	1572	

Ru: *R. usambarensis*; Si: *S. incanum*; Su: Sucrose; Wa: Water;  
 OR: Oviposition rate; HR: Hatching rate; EmR: Emergence rate;  
 (): Percentages are referred to the ratios of the numbers for a given stage over the number of the immediately preceding one.  
 Vertical means followed by the same letter are not significantly different at  $P \geq 0.05$ ; SE: Standard error.



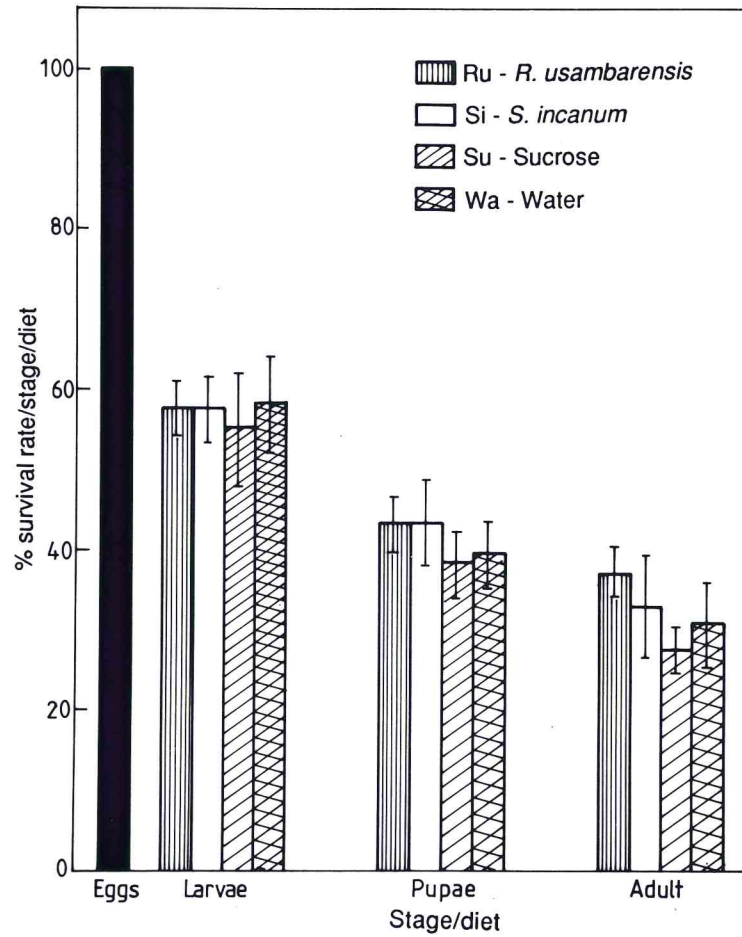

Figure 11: % survival of developmental stages of the progeny, with reference to eggs, when *P. duboscqi* females were maintained on different diets during the pre-oviposition period.

**d. Reproductivity and sex-ratio**

The numbers of adults produced in the progeny over the total number of the females laying eggs were referred to as total reproductivity (TR) while the number of females in the progeny over the number of females in the parental batch is called effective reproductivity (ER). The reproductivity was not affected by the difference in diets; the sex-ratio was almost the same under other diets but significantly in favour of males in the progeny whose parental females had been maintained on water during the pre-oviposition period (Table 47, Appendix 17).

**Table 47:**  
**Reproductivity of *P. duboscqi* females and sex-ratio of the progeny when the former were maintained on different diets during the pre-oviposition period.**

Diet	Number, reproductive rate and sex-ratio (Mean ± SE)									
	Status/rate									
	Laying	TR	Adults	Females	Males	Sex-ratio	ER			
Ru	108	19.92 ± 1.74a	2151	996	1155	0.46 : 0.54ab	9.22 ± 0.67a			
Si	106	16.04 ± 1.79a	1737	866	871	0.50 : 0.50a	8.17 ± 0.92a			
Su	115	14.05 ± 1.69a	1631	782	849	0.48 : 0.52ab	6.80 ± 0.75a			
Wa	109	14.00 ± 2.85a	1572	696	776	0.44 : 0.56b	6.34 ± 1.15a			

R: *R. usambarensis*; Si: *S. incanum*; Su: Sucrose; Wa: Water;  
 TR: Total reproductive rate; ER: Effective reproductive rate;  
 Vertical means followed by the same letter are not significantly different at  $P \geq 0.05$ ; SE: Standard error.

#### 4.4.1.3 Discussion

Sugars have been found necessary for insect reproductive system by enhancing the functioning of the spermatogenesis in males and the vitellogenesis in females. Carbohydrates have been reported to be a limiting factor for fecundity in females of grain-feeding beetles (*Sitophilus* sp.) (Huffacker *et al.*, 1984). Endris *et al.* (1984) in a comprehensive study on the laboratory biology of *Lu. anthophora* found a significant difference between the average numbers of eggs laid by females given blood meal (40.8) and those in which blood meal was supplemented with sugar (49.7).

Observations in nature showed that females of *Leptinotarsa* sp. fed on young leaves of various plants laid a higher number of eggs than those fed on old leaves (Huffaker *et al.*, 1984). In the present study a significant difference in fecundity due to different diets was observed among the females of both *S. ingrami* and *P. duboscqi*: *R. usambarensis* was associated with a significantly higher number of eggs per female in the two sandfly species but the lowest fecundity was associated with *S. incanum* in *S. ingrami* while water exhibited the lowest number of eggs in *P. duboscqi*. The difference in fecundity was (statistically) reflected in the reproductive rate in *S. ingrami* but not in *P. duboscqi*. However, if the difference found at egg level can, at a certain extent, have a negligible impact the same (even a smaller one) difference at adult level may have significant biological and epidemiological implications (especially when dealing with an insect

vector like in the present study) which are not always detected by statistical analysis. In the present study the mean number of eggs laid by *P. duboscqi* females given *R. usambarensis* (54.03) or sucrose (51.82) can be paralleled to those recorded in comparable context and circumstances by Killick-Kendrick *et al.* (1977) with *P. longipalpis* (50) fed on sucrose, Chaniotis (1986) with *Lu. trapidoi* fed on sucrose (39.3), Mutinga *et al.* (1987) with *P. duboscqi* given sliced apples (40) and Perkins *et al.* (1990) with *P. papatasi*, *P. argentipes*, *P. duboscqi* and *P. longipalpis* (30-50) given a karo syrup.

Chaniotis (1986), in an attempt to relate fecundity and egg development period of *Lu. trapidoi*, found that shorter oogenesis periods resulted in higher number of eggs and better female survival whereas longer periods (> 9 days) were less productive and reduced the probability of female surviving after oviposition. The decrease of egg productivity was observed in the present study with *S. ingrami* laying after 7 days (mean = 5.62 days with sucrose) and with *P. duboscqi* laying after 10 days (mean = 8.24 days with sucrose).

With *P. duboscqi* fed on sucrose and maintained at 27° C Mutinga *et al.* (1987) found a mean gonotrophic cycle (equal to pre-oviposition period if the laying female is refed the day of oviposition) of 5.2 days. Endris *et al.* (1984) observed a longer pre-oviposition period when *Lu. anthophora* was supplemented with sucrose (4.5 days) as compared to the batch given blood meal only (6.2) days. The embryonation period which was in average 5 and 6 days for *S. ingrami* and *P. duboscqi*, respectively,

was consistent with the findings by Mutinga *et al.* (1989) reporting an embryonation duration of 5.8 days for *S. ingrami* and 8.9 days for *P. duboscqi*. The developmental period (egg to adult) is most likely dependent upon experimental conditions to which immature stage is sensitive such as food quality and quantity (Killick-Kendrick, 1977; Chaniotis, 1986; Perkins *et al.* 1990). In the present investigation rabbit chow and rabbit feces (1:1) ground together (Young *et al.*, 1981; Mutinga *et al.*, 1989, Perkins *et al.*, 1990) was the staple diet for larval stage of *S. ingrami* and *P. duboscqi* and was the same irrespective of the diet of the parental females. At  $28.5 \pm 0.3^\circ \text{C}$  and 60-70% Rh and with the diet described above the life cycle was completed approximately in 29 days by *S. ingrami* and 34-36 (according to diet) days by *P. duboscqi*. These results are consistent with those obtained by Endris *et al.* (1984) with *Lu. anthophora* at  $28^\circ \text{C}$  (39 days), Chaniotis (1986) with *Lu. trapidoi* at  $26.7^\circ \text{C}$  (33-47 days).

The developmental survival was not significantly affected by the difference in diet and the biggest loss was situated at the hatching stage in each sandfly species and each diet. As for the numbers of adults produced at the end of the process, *S. ingrami* seemed more prolific (25-34 adults per female) than *P. duboscqi* (14-19 adults per female). Endris *et al.* (1984) obtained the best developmental survival when the immature stage of *Lu. anthophora* was kept at  $28^\circ \text{C}$  where larvae hatched from 41 eggs developed to 36 adults as compared with 59 eggs ending up to 19 adults at  $20^\circ \text{C}$  or 104 eggs giving 88 adults at  $32^\circ \text{C}$ .

The sex-ratio in *S. ingrami* did not show any significant difference due to the diets but in *P. duboscqi*, the progeny from the batches maintained on water had more males than females (696 vs 776). However, that imbalance which seems to be detrimental for the fecundity in terms of potential egg production, would be compensated for by enhanced fertility as Chaniotis (1986) demonstrated that the presence of 2 males in individual oviposition vials containing 1 female increased the fecundity by approximately 50%.

## 4.4.2 Longevity

### 4.4.2.1 *S. ingrami*

The maximum longevity associated with the four diets were as follows: 28, 24, 21 and 9 days for *R. usambarensis*, sucrose, *S. incanum* and water, respectively, with their corresponding means, in the same order, 24.6, 18.6, 17.4 and 8.4 days. The average means through all the observations (mean longevity for individual fly) were 12.8 for *R. usambarensis*, 8.8 for *S. incanum*, 9.8 for sucrose and 4.7 for water. *R. usambarensis* was associated with the best longevity in terms of the longest lived individuals as well as the average survivorship (Table 48). Water was found to yield the lowest longevity while sucrose and *S. incanum* occupied intermediate position. Longevity seemed to be significantly affected by the diets ( $F = 21.98$ ;  $df = 3$ ;  $P < 0.001$ ). The same observation holds when cumulative mortalities were converted into quantiles (Table 49). This method showed that 50% of the population died within 13 days when flies were maintained on *R. usambarensis*, 10 on sucrose, 9 on *S. incanum* and 5 on water. A 100% of the population was exhausted by the 28th day under *R. usambarensis*, 24th under sucrose, 21st under *S. incanum* and 9th under water. The pattern of the cumulative mortality is illustrated by Fig.12.



Table 48:

Longevity (days) of adult *S. ingrami* maintained on different diets.

Diet	N	Mean $\pm$ SE	
		Maximum average	General average
Ru	5	24.6 $\pm$ 1.8a	12.2 $\pm$ 2.0a
Si	5	17.4 $\pm$ 1.2b	8.8 $\pm$ 1.9b
Su	5	18.6 $\pm$ 1.4b	9.8 $\pm$ 1.5b
Wa	5	8.4 $\pm$ 0.4c	4.7 $\pm$ 0.2c

Ru: *R. usambarensis*; Si: *S. incanum*; Su: Sucrose; Wa: Water;

N: Number of experiments for each diet;

Vertical means followed by the same letter are not significantly different at  $P \geq 0.05$ ; SE: Standard error.

**Table 49:**  
**Cumulative mortality (quantile method) of adult *S. ingrami* maintained on different diets.**

CM	Q	Number of days/quantile/diet			
		Ru	Si	Su	Wa
100%	Maximum	28	21	24	9
75%	Q <sub>3</sub>	19	14	14	7
50%	Median	13	9	10	5
25%	Q <sub>1</sub>	7	5	5	3
0%	Minimum	1	1	1	1
	Range	27	20	23	8
	Q <sub>3</sub> - Q <sub>1</sub>	12	9	9	4
	Mode	1	1	1	1

CM: Cumulative mortality; Q: Quantile;  
 Ru: *R. usambarensis*; Si: *S. incanum*; Su: Sucrose; Wa: Water.

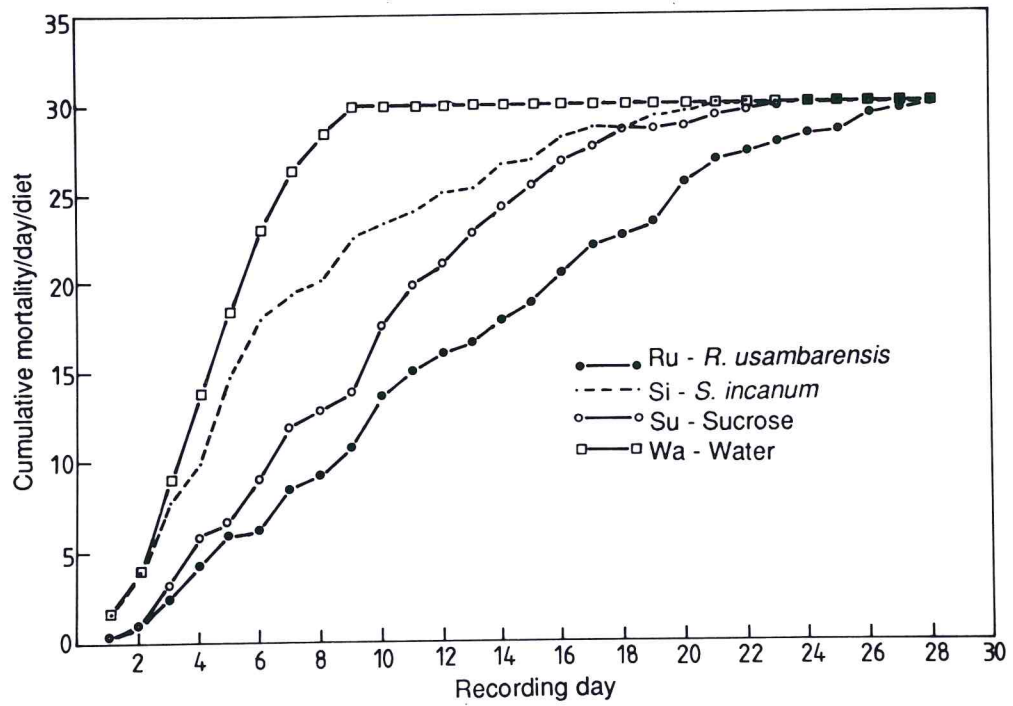

Figure 12: Cumulative adult mortality of *S. Ingrami* maintained on *R. usambarensis*, *S. incanum*, sucrose and water.

#### 4.4.2.2. *P. duboscqi*

The maximum longevity is given in Table 50 for different diets: 41, 44, 27, and 17 days for, *R. usambarensis*, sucrose, *S. incanum*, and water, respectively; the corresponding means were 30.6, 26.0, 17.4 and 13.4 days, the overall means being, 15.7, 13.5, 9.3, and 7.2 days, respectively. The quantile method (Table 51) shows that only 25% of flies lived respectively up to 23 days with *R. usambarensis*, 20 with sucrose, 14.5 with *S. incanum* and 11 days while the pattern of cumulative mortality indicates that the last contingents had died by the days 44 (sucrose), 41 (*R. usambarensis*), 27 (*S. incanum*) and 17 (water). In all cases there was a highly significant effect of diets on the longevity of *P. duboscqi* ( $F = 14.24$ ;  $df = 3$ ;  $P < 0.001$ ). The above means can be divided into two groups: a relatively higher longevity in the flies maintained on *R. usambarensis* or sucrose and a lower longevity in those given *S. incanum* or water.

Table 50:

Longevity (days) of adult *P. duboscqi* maintained on different diets.

Diet	N	Mean $\pm$ SE	
		Maximum average	General average
Ru	5	30.6 $\pm$ 2.4a	15.7 $\pm$ 1.2a
Si	5	17.4 $\pm$ 2.6b	9.3 $\pm$ 1.3b
Su	5	20.0 $\pm$ 4.2a	13.5 $\pm$ 2.0a
Wa	5	13.4 $\pm$ 1.3b	7.2 $\pm$ 0.7b

Ru: *R. usambarensis*; Si: *S. incanum*; Su: Sucrose; Wa: Water;

N: Number of experiments for each diet;

Vertical means followed by the same letter are not significantly different at  $P \geq 0.05$ ; SE: Standard error.

**Table 51:**

**Cumulative mortality (quantile method) of adults *P. duboscqi* maintained on different diets.**

CM	Q	Number of days/quantile/diet			
		Ru	Si	Su	Wa
100%	Maximum	41	27	44	17
75%	Q <sub>3</sub>	23	14.5	20	11
50%	Median	16	9	13.5	7
25%	Q <sub>1</sub>	8	5	7	4
0%	Minimum	1	1	1	1
	Range	40	26	43	16
	Q <sub>3</sub> -Q <sub>1</sub>	15	9.5	13	7
	Mode	1	1	1	1

CM: Cumulative mortality; Q: quantile;  
 Ru: *R. usambarensis*; Si: *S. incanum*; Su: Sucrose; Wa: Water.

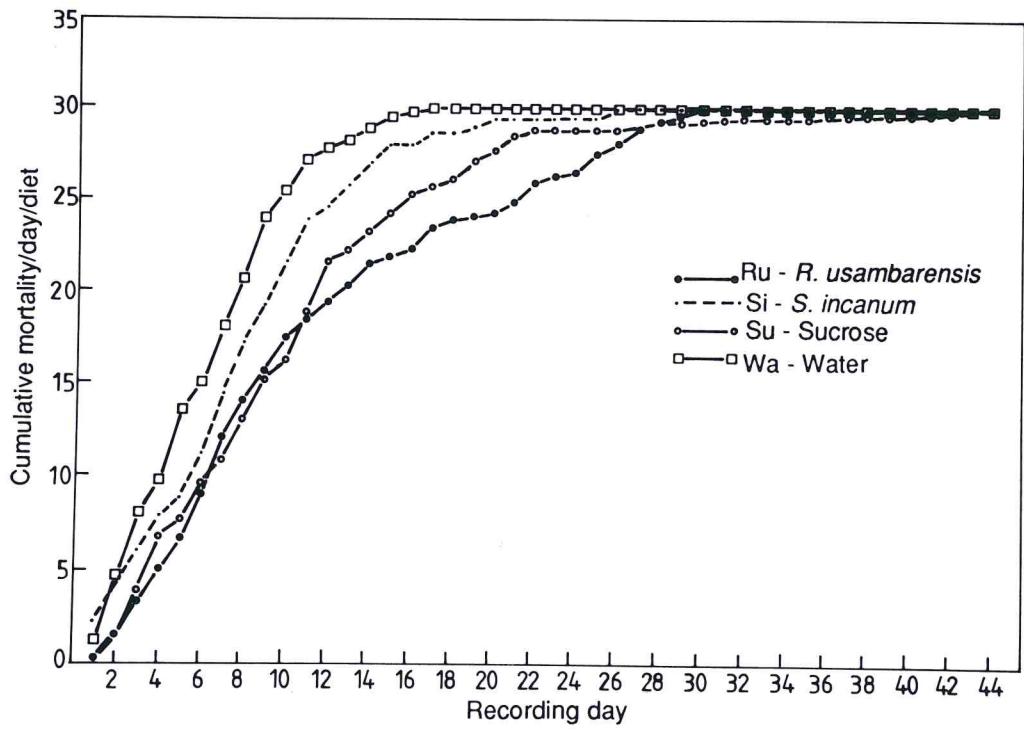

Figure 13: Cumulative adult mortality of *P. duboscqi* maintained on *R. usambarensis*, *S. incanum*, sucrose and water.

#### 4.4.2.3 Discussion

Among the four diets, water produced the lowest longevity for *S. ingrami* and *P. duboscqi*, but *S. incanum* appeared to share the same property in the case of *P. duboscqi*. And noteworthy, *S. incanum* was associated with almost the same longevity in *S. ingrami* and *P. duboscqi*, suggesting that if that plant had any effect, it would not be species specific to the sandfly. With *S. ingrami*, sucrose and *S. incanum* were not significantly different but with *P. duboscqi*, sucrose was more close to *R. usambarensis*.

Suitable plants -such as *C. spinosa* fed to *P. papatasi*- have proven to enhance longevity but not at the same degree as sucrose (Killick-Kendrick, 1987). Mutinga *et al.* (1987) successfully maintained *P. duboscqi* (on apple fruit) through 8 gonotrophic cycles completed in 45 days. In the present study with *P. duboscqi*, the longest life span recorded (44 days) was achieved by 1 individual (*female*) fed on sucrose, but this one was challenged by 1 individual (*male*) from the batches maintained *R. usambarensis* which lived up to 41 days. It should not be found surprising if in some cases, especially in experimental studies where flies are denied blood meal, a suitable plant enhanced longevity in a given hemato-phytophagous insect because in addition to carbohydrates plant sap contains other nutrients such as amino acids, proteins, lipids, vitamins, minerals, etc. (Kevan and Parker, 1984). A positive correlation ( $R = 0.6383$ ;  $P \leq 0.05$ ) was found between feeding rate and longevity.



## 4.5 *Leishmania* infectivity

### 4.5.1 Infection rate

Four days (incubation period) after the infective blood meal, 4 live flies and all those found dead were picked daily from the batches maintained respectively on *R. usambarensis*, *S. incanum*, sucrose and water, they were dissected and the results recorded as in Table 52; thus, the number of dissected and the number of positive include both live and dead specimens.

The infection rate (Table 53) which was found significantly different with diets ( $F = 3.31$ ;  $Df = 3$ ;  $P < 0.05$ ) divided the batches into two groups: one associated with relatively higher infection rate, represented by *R. usambarensis* and sucrose, and the other associated with a lower infection rate, comprising *S. incanum* and water.

**Table 52:**

**Record of infection by *L. major* to *P. duboscqi* maintained on different diets after infective blood meal.**

Diet	Ru			Si			Su			Wa		
Rep	FD	ND	NP	FD	ND	NP	FD	ND	NP	FD	ND	NP
1	30	26	10	40	36	8	29	29	12	35	29	5
2	32	26	9	32	32	4	38	38	5	40	32	12
3	27	27	7	25	17	2	23	23	8	31	28	3
4	32	32	11	29	28	8	29	29	9	30	27	2
5	30	24	7	34	33	6	38	38	17	34	29	7

Ru: *R. usambarensis*; Si: *S. incanum*; Su: Sucrose; Wa: Water;  
FD: Number of flies fed on infective blood meal; ND: Number of flies dissected; NP: Number of positive for *Leishmania* parasites.

Table 53:

*L. major* infection rate in *P. duboscqi* maintained on different diets after infective blood meal.

Diet	N	% (Mean $\pm$ SE)
Ru	5	32.51 $\pm$ 2.21a
Si	5	18.65 $\pm$ 3.14b
Su	5	33.02 $\pm$ 5.52a
Wa	5	19.40 $\pm$ 5.36b

Ru: *R. usambarensis*; Si: *S. incanum*; Su: Sucrose; Wa: Water;

N: Number of experiments for each diet;

Means followed by the same letter are not significantly different at  $P \geq 0.05$ ;

SE: Standard error.

#### 4.5.2 Location and quality of parasites as an indication of transmission potential

Tables 54-57 present the position of *L. major* promastigotes in the principal sections of sandfly gut (Plate 18) with reference to *P. duboscqi* maintained respectively on *R. usambarensis*, *S. incanum*, sucrose and water, and dissected on a daily basis, starting from the 4th day after the infective blood meal. In the flies maintained on *S. incanum* or water (Tables 55 and 57), the parasites were observed in the abdominal and thoracic midgut with very few specimens in the foregut; whereas in those fed on *R. usambarensis* or sucrose (Tables 54 and 56) parasites were found in abdominal and thoracic midguts, with a good proportion in the foregut as well. In a few cases, parasites were also found in the pharynx and beyond, in flies fed on *R. usambarensis* or sucrose. Apart from one fly (from the batch maintained on sucrose) the hindgut was generally clean of parasites. In some flies maintained on *S. incanum* or water parasites were found forming a rosette-like cluster, and particularly under the water diet, flies several flies were harbouring sluggish and dead-like parasites (Plate 19). Parasites reaching the foregut and beyond were very active and motile.

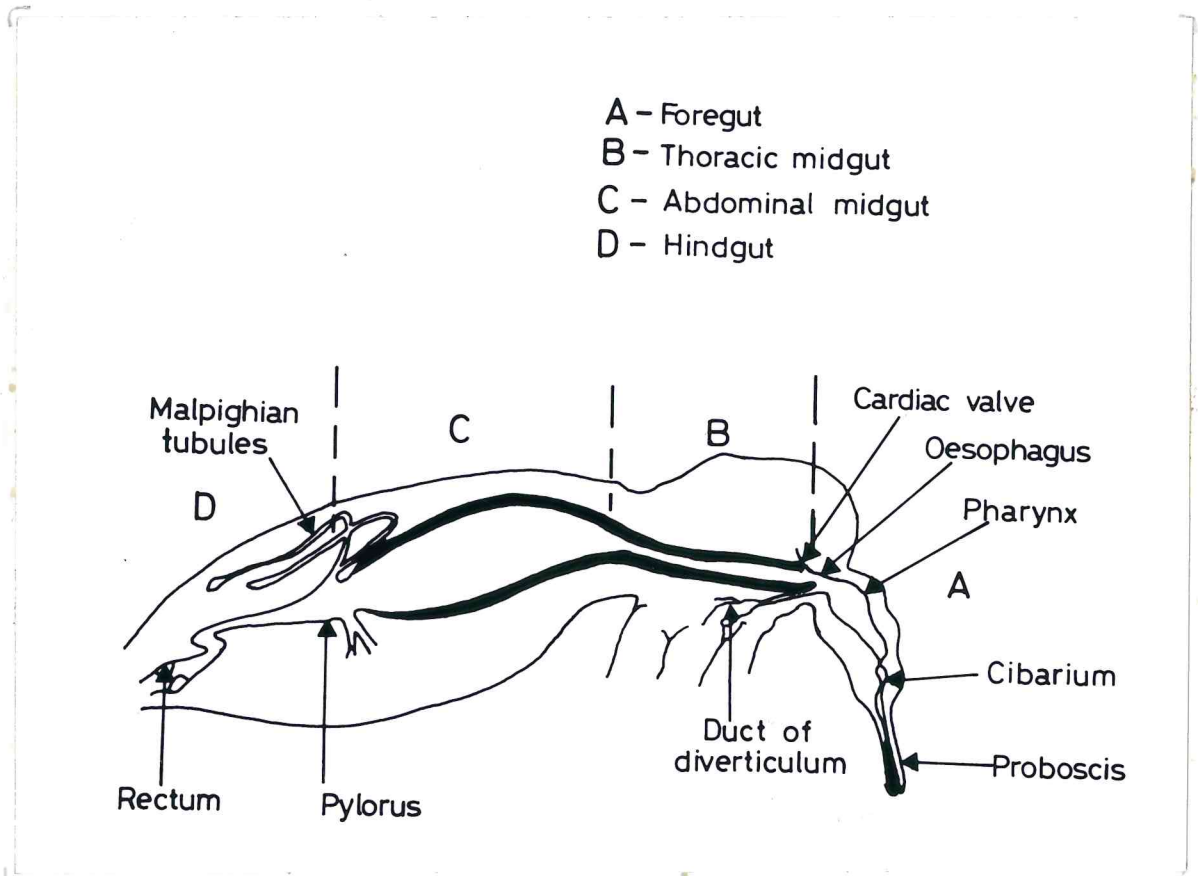

Plate 18: Diagram showing the partition of sandfly gut.

Table 54:

Location of *L. major* promastigotes in the gut of *P. duboscqi* maintained on *R. usambarensis*, after infective blood meal (infectivity potential).

Dissection day	Infected flies	Part of gut				
		HG	AMG	TMG	FG	PHX
4	3	-	+	+		
5	4	-	+	+		
6	6	-	+	+		
7	7	-	+	+	+	
8	4	-	+	+	+	
9	3	-	+	+	+	
10	4	-	+	+	+	+
11	3	-	+	+	+	
12	4	-	+	+	+	+
13	2	-	+	+	+	
14	2	-	+	+		
15	2	-	+	+		

HG: Hind gut; AMG: Abdominal midgut; TMG: Thoracic midgut; FG: Foregut;  
 PHX: Pharynx;  
 -: Absence of infection; +: Presence of infection.

Table 55:

Location of *L. major* promastigotes in the gut of *P. duboscqi* maintained on *S. incanum*, after infective blood meal (infectivity potential).

Dissection day	Infected flies	Part of gut			
		HG	AMG	TMG	FG
4	4	-	+	+	
5	6	-	+	+	
6	2	-	+	+	
7	3	-	+	+	
8	3	-	+	+	
9	5	-	+	+	+(1)
10	5	-	+	+	+(1)

HG: Hindgut; AMG: Abdominal midgut; TMG: Thoracic midgut; FG: Foregut;  
-: Absence of infection; +: Presence of infection;  
(): Number of flies with parasites in the indicated part of gut.

Table 56:

Location of *L. major* promastigotes in the gut of *P. duboscqi* maintained on sucrose, after infective blood meal (infectivity potential).

Dissection day	Infected flies	Part of gut				
		HG	AMG	TMG	FG	PHX
4	6	-	+	+		
5	6	-	+	+	+(1)	
6	4	-	+	+	+(2)	+(1)
7	5	-	+	+		
8	7	-	+	+		
9	5	+?	+	+		
10	6	-	+	+	+(3)	+(1)
11	3	-	+	+		
12	3	-	+	+		
13	4	-	+	+	+(1)	
14	2	-	+	+		

HG: Hindgut; AMG: Abdominal midgut; TMG: Thoracic midgut; FG: Foregut; PHX: Pharynx; -: Absence of infection; +: Presence of infection; (): Number of flies with parasites in the indicated part of gut.

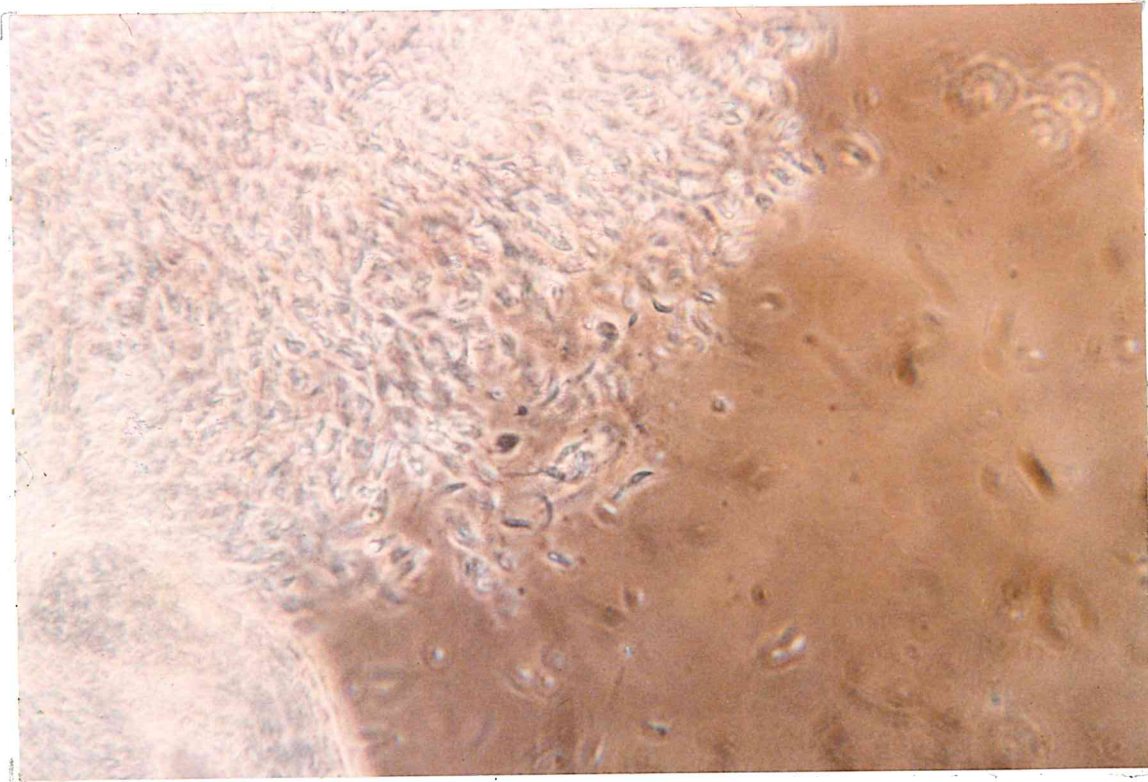

Table 57:

Location of *L. major* promastigotes in the gut of *P. duboscqi* maintained on water, after infective blood meal (infectivity potential).

Dissection day	Infected flies	Part of gut				(0)
		HG	AMG	TMG	FG	
4	2	-	+			
5	5	-	+	+		
6	9	-	+	+		
7	2	-	+	+		((2))
8	3	-	+	+		
9	3	-	+	+		
10	1	-	+	+		
11	1	-	+	+	+(1)	
12	2	-	+	+		((2))
13	1	-	+	+		

HG: Hindgut; AMG: Abdominal midgut; TMG: Thoracic midgut; FG: Foregut;  
 PHX: Pharynx; -: Absence of infection; +: Presence of infection;  
 (): Number of flies with parasites in the indicated part of gut;  
 (()): Number of flies with sluggish and dead-looking promastigotes in the midgut, some produced clusters in the proventricular (cardiac valve) region.



**Plate 19:** Cluster of sluggish and dead-looking *L. major* promastigotes in the gut of *P. duboscqi* maintained on water after infective blood meal (cardiac valve between thoracic midgut and foregut).

### 4.5.3 Discussion

The infection rate recorded in *P. duboscqi* infected by *L. major* in the present study which ranged from 19.40% (flies maintained on water after infective blood meal) to 33.02% (flies maintained on sucrose after blood meal) is far from the 100% infection rate obtained by Pozio *et al.* (1985) working on *P. perniciosus* maintained on sucrose after infective blood meal taken through feeding membrane. Of course, the feeding membrane method used by the mentioned authors is likely to yield a higher infection rate as compared with the infection by feeding flies on an infected animal, since with the latter method the infectivity will depend, among other things, on the number of amastigotes taken by the sandfly and the probability of some flies to feed on unparasitised areas (Kaddu *et al.*, 1986).

Also the age of the sandfly colony may affect its susceptibility, and within the same species of parasite, the infectivity may vary according to the strain (Endris *et al.*, 1987; Evans, 1989). On the other hand, microbial contamination of the sandfly gut has been found to be a major snag to the development of *Leishmania* parasites (Adler and Theodor, 1957; Schlein *et al.*, 1986) despite the existence of antibacterial factor meant to help keep clean the sandfly gut (Schlein *et al.*, 1986). Since after the infective blood meal, the flies were kept under the same conditions apart from the diets, the latter are the suspected factors to account for the difference observed in the infection rate, location and quality of the parasites.

Furthermore, the determination of an optimum temperature had been for long time one of the problems making difficult the experimental transmission of *Leishmania* until satisfactory results were obtained when *P. argentipes* was kept at  $27.5 \pm 0.5^\circ \text{C}$  (Adler and Theodor, 1957). So in the present study, the same temperature was kept in the incubators containing cages with infected flies.

*R. usambarensis* and sucrose had respectively 10 and 8 flies with parasites in the foregut some of which were observed in the pharyngeal region while *S. incanum* and water had much less (2 and 1, respectively) reaching the foregut, almost in the same proportion as the infection rate. While many parasites from the batches maintained on sucrose or *R. usambarensis* were very active and moving through the foregut to the mouthparts; in contrast, some flies maintained on water had clusters of sluggish parasites in the thoracic midgut or in a rosette form and dead-looking around the cardiac valve. It was surprising to find one sandfly with a few parasites moving in the hind gut though *L. major* belongs to the suprapylarian group (Lainson and Shaw, 1979). But Endris *et al.* (1987) had observed also some parasites of *L. mexicana* (which belongs to the same group) moving freely in the hind gut of *Lu. anthophora* but without attaching on the gut wall.

It has been established that migration of *Leishmania* from midgut to foregut and the proboscis of the sandfly vector is a prerequisite for transmission by bite (Adler and Theodor, 1957; Killick-Kendrick, 1977, 1979; Molyneux and Ashford, 1983; Schlein, 1993). This migration of parasites to

the proboscis leading to the transmission by bite of sandfly vectors involves a complex of physiological and morphological changes (Molyneux *et al.*, 1975; Molyneux and Killick-Kendrick, 1987) from dividing organisms during the logarithmic phase (non-infective promastigotes) to non-dividing organisms during stationary phase (infective promastigotes). These different phases and changes have been well documented in several works and reviews, e.g. by Sacks and Perkins (1985) and Schlein (1993).

The role of sugar is closely associated with the history of experimental transmission of leishmaniasis. As reported by Adler and Theodor (1957) and Killick-Kendrick (1979) the laboratory transmission of Indian kala-azar (*L. donovani*) by *P. argentipes* was easily achieved when infected sandflies were allowed to feed on raisins before refeeding on human volunteer or experimental animal. It was assumed that in the foregut, a quite barren medium lined by cuticular intima in the absence of blood and blood digestion products, sugars which are taken into the crop and gradually delivered into the gut would be the only source of nutrients and energy for migrating parasites (Killick-Kendrick, 1977; Young, 1980). However, it appeared that the transmission of *L. infantum* which became unpredictable when the vector *P. ariasi* was routinely fed on artificial sugars and raisins had improved when laboratory infected flies were released and recaptured. This suggests that natural sugars taken in the wild are accompanied by other ingredients, which probably enhance the development and the transmission of *Leishmania* by bite (Killick-Kendrick, 1977, Young, 1980). Warburg and Schlein (1986) demonstrated that the production of infective forms of *L. major* was superior

when experimentally infected *P. papatasi* was maintained on sugar with serum as a source of amino acids as compared with the production when the vector was maintained on sugar alone. Furthermore, it has been found that in addition to carbohydrates, plant sap contains other nutrients such as amino acids, proteins, lipids, vitamins, minerals, etc. (Kevan and Parker, 1984).

In addition to the nutritional importance, MacVicker (1990) reported findings suggesting a significant role of sugars in determining the behaviour of *Leishmania* in the gut of sandflies. For instance, *L. major* promastigotes have been shown to undergo selective changes in surface carbohydrates, determined by their agglutination by plant lectins and these changes paralleled the development from non-infective to infective promastigotes (Sacks and Perkins, 1984). If the growth in sugar medium induce transformation of *Leishmania* in the same manner as it is observed in the sandfly gut as suggested by Schlein *et al.*, 1987), that would constitute a sound support to the postulation that carbohydrates - lectins - *Leishmania* interaction governs the development and infectivity of the parasites within the vector, the sugar feeding being integral to the system (Blackwell, 1985).

## CHAPTER 5

### GENERAL DISCUSSION AND CONCLUSION

#### 5.1 Phytophagy

The phytophagy of *S. ingrami* and *P. duboscqi* was demonstrated, through anthrone test, by the presence of sugar in the guts of flies fed on the plant materials thoroughly washed to rule out any sugar of external source. For a given sandfly species the feeding response is plant specific but the age and texture of the plant materials may also play a significant role.

#### 5.2 Sugar content in the test plants

The two modes of extraction affected differently the output of the test in different plants. With the extracts by direct extraction, *A. indica* and *T. minuta* were found with the highest sugar concentration while in those obtained by sequential extraction, *O. kenyense* and *M. azedarach* were the richest in carbohydrates, and in all the cases *O. suave* was the poorest in sugar content. The difference in sugar content between the two modes of extraction in general is due to the fact that the procedures applied on the extracts from the sequential extraction were meant to concentrate sugars at

each step, but an unknown amount of sugar is likely to have been lost through the previous solvents, especially the methanol phase.

Therefore the direct extraction is most likely to give a rough idea of the free and mobile sugars most readily available to feeding of sandflies.

The fact that *T. minuta*, *O. kenyense* and *A. indica*, which were relatively low in feeding, rate turned up to be the richest in sugar content, suggests that there should be, in addition to sugar content, other factors involved in sandfly phytophagy.

### **5.3 Bioassay for assessing the behavioural responses by *P. duboscqi* to olfactory stimuli from some plant species previously tested for phytophagy**

The bioassay test revealed that *M. azedarach* and *R. usambarensis* were attractants while *O. suave* and *T. minuta* behaved as repellents to *P. duboscqi*. This suggests that the feeding response of sandflies is strongly correlated with the attractancy/repellency of host plants.

### **5.4 Effects of plant diets on sandfly biology**

Results from the experiments on some aspects of sandfly biology suggest that plant feeding not only does it supply carbohydrates as source of energy for activity and maintenance but also significantly influences fecundity in sandflies. Developmental duration and survival were not significantly



affected by the diets, meaning that the effect of plant diets taken by the parental females during the pre-oviposition period was not significantly reflected in the immature stage of progeny, the latter depending mainly on the rearing-medium conditions (larval diet, temperature and humidity, presence/absence of predators and/or pathogens ...).

Effective reproductivity and adult longevity were among the most important aspects of sandfly biology significantly sensitive to the difference in diets.

### **5.5 Plant diets and *Leishmania* infectivity in *P. duboscqi***

Infection rates from the dissections of *P. duboscqi* maintained on different diets after the infective blood meal, showed that *R. usambarensis* and sucrose are more favorable than *S. incanum* and water for the development and migration of *L. major*. Observations on the infection rate, quality and location of parasites suggest that *R. usambarensis* and sucrose are more likely to enhance the ability of *P. duboscqi* to develop and transmit *L. major* by bite as compared to *S. incanum* and water.

## CHAPTER 6

### SUMMARY OF THE MAIN FINDINGS AND SUBSEQUENT QUESTIONS IN THE STUDIED AREA

#### 6.1 Findings

##### (a) From a global point of view

On the basis of to the literature consulted on the subject, it appeared that this is the first time such an investigation was carried out in an attempt to understand the plant-vector-parasite relationships with reference to *Leishmania* parasites and phlebotomine sandflies using Kenyan sandfly and plant materials.

##### (b) From a specific point of view

(i) This study has provided an additional evidence to the question as to whether sandflies can get sugars directly by sucking the plant sap.

(ii) Un experiment was conducted to assess the relationship between the feeding responses of phlebotomine sandflies and the sugar content of the host plants.

(iii) The apparatus designed for assessing the behavioural responses by phlebotomine sandflies to olfactory stimuli from some plant species plants permitted to demonstrate that *R. usambarensis* and *M. azedarach* were attractants while *O. suave* and *T. minuta* were repellents to *P. duboscqi*.

(iv) Specific improvements and innovations have been achieved to maximise/optimize the results of certain experiments.

- Modifications brought to the individual oviposition vial allowed to ensure the permanence of diet for sustenance of adult flies and moisture for oviposition.

- The moisture keeping device allowed a better handling of individual oviposition vials grouped by diet and provided an uninterrupted moisture supply to each oviposition vial.

- The couple temperature-humidity (28.5° C/60-70% Rh) proved suitable for a high output in the biological parameters investigated.

The above improvements singly or in combination resulted in the high level of fecundity, the relative reduction of the life cycle duration, the high rates of reproductivity of the parental females batch, the survival of the progeny and a high adult longevity. They also created relatively favorable conditions to the development and infectivity potential of *L. major* (ICIPE 226) to the laboratory-reared *P. duboscqi*.

## 6.2 Outstanding questions

Answers to initial questions in direct connection with the objectives of the study opened the way to subsequent questions some of which remained unanswered and call for further investigations, e.g.:

(a) Laboratory experiments on phytophagy and behavioural response by the test sandflies to the test plants necessitate comparative experiments in the field, especially in the known foci of leishmaniasis.

- (b) In addition to qualitative results on sandfly phytophagy obtained by anthrone test, quantitative and analytical approaches (chemical analysis) are needed to identify and quantify not only sugars but also other compounds ingested with the plant sap (e.g. lectins).
- (c) Plant species such as *A. indica* and *M. azedarach* which have been reported to have anti-feedant and development-inhibiting effect on several insect species had medium to very high feeding rates in *S. ingrami* and *P. duboscqi*; it would be interesting to assess the effect of their ingesta on the biology and vector competence of sandflies.
- (d) Phytophagy in general and phyto-lectins in particular may play determinant roles in the infectivity potential and cyclical transmission of *Leishmania* parasites through the bites of sandfly vectors; in depth investigations should be undertaken in this area.
- (e) Data on the distribution and abundance of parasites in different sections of the gut of sandflies maintained on different plant species would help evaluate the effects of plant diets on the infectivity potential of a given *Leishmania* strain in the test sandfly vector; etc.

## REFERENCES CITED

- Abonnenc, E. (1972). Les Phlébotomes de la Région éthiopienne (Diptera, Psychodidae). O.R.S.T.O.M. Paris, 289 pp.
- Adler, S. and Theodor, O. (1957). Transmission of the Disease Agents by Phlebotomine Sand Flies. **Ann. Rev. Entomol.** **2**, 203-226.
- Agnew, A.D.Q. (1974). Unplanted Kenyan Wild Flowers. A flora of ferns and herbaceous flowering plants of Upland Kenya. Oxford University Press, Nairobi, 827 pp.
- Akobundu, O.I. (1987). Weed Science in tropics. Principles and practices. John Wiley & Sons, New York, 521 pp.
- Ali, M. (1976). Study on the induction of feeding preference in alfalfa ladybird, *Subcoccinella 24-punctata* L. (Coleoptera: Coccinellidae). In The host-plant in relation to insect behaviour and reproduction (Ed., Jermy, T.). **Symp. Biol. Hung.** **16**, 23-28.
- Ashford, R.W. (1974). Sandflies (Diptera: Psychodidae) from Ethiopia: Taxonomy and Biological Notes. **J. Med. Ent.** **11** (5): 605-616.
- Ashford, R. W. (1988). Reservoir hosts of Leishmaniases and their control. Proceedings of International Workshop held in Ottawa, Canada, 1-4 June 1987, pp. 317-322.

- Ashford, R.W. and Bettini, S. (1987). Ecology and Epidemiology: Old World. **In:** Leishmaniasis in Biology and Medicine. Volume I. Biology and Epidemiology (Eds, Peters, W. and Killick-Kendrick, R.). Academic Press, London, pp. 365-424.
- Asimeng, E.J. (1985). The distribution of *Phlebotomus duboscqi* with reference to the known foci of cutaneous leishmaniasis in Northern Nigeria. **Insect Sci. Applic.** **6**, 27-31.
- Auclair, J.L. (1963). Aphid feeding and nutrition. **Ann. Rev. Entomol.** **8**, 439-490.
- Auclair, J.L. (1976). Feeding and nutrition of pea aphid *Acyrtosiphon pisum* (Harris) with special reference to amino acids. **In:** The host-plant in relation to insect behaviour and reproduction (Ed., Jermy. T.). **Symp. Biol. Hung.** **16**, 29-34.
- Aulakh, B.S. and Rimkus, A.J. (1987). Some agronomic aspects of rainfed wheat production in northern Zambia. Fifth Regional Wheat Workshop for Eastern, Central and Southern Africa and Indian Ocean. Mexico City. Mexico, CIMMYT, pp. 194-201.
- Basimike, M. (1990). Temperature and moisture content of soil of termite mounds and animal burrows in relation to relative abundance of adult phlebotomine sandflies (Diptera:Psychodidae) in Marigat semiarid area, Baringo District, Kenya. **Env. Entomol.** **19** (3): 486-489.

- Basimike, M. Mutinga M. J. and Kumar R. (1991). Distribution of sandflies (Diptera: Psychodidae) in three vegetation habitats in the Marigat area, Baringo district, Kenya. **J. Med. Entomol.** **28** (3): 330-333.
- Basimike, M.; Mutinga, M. J. and Mutero, C. M. (1989). Vertical distribution of phlebotomine sandflies in the two habitats in Marigat Leishmaniasis endemic focus, Baringo, District, Kenya. **Insect Sci. Applic.** **10** (5): 645-650.
- Beach, R.; Kiilu, G.; Hendrikcs, R.; Oster, C. and Leeuwenburg, J. (1984). Cutaneous Leishmaniasis in Kenya. Transmission of *Leishmania major* to man by bite of naturally infected *P. duboscqi*. **Trans. R. Soc. trop. Med. Hyg.** **78**, 747-751.
- Beach R.; Young, D.G. and Mutinga, M.J. (1983). New phlebotomine sandfly colonies. Rearing *Phlebotomus martini*, *Sergentomyia schwetzi* and *S. africana* (Diptera, Psychodidae). **J. Med. Entomol.** **20**, 579-589.
- Blackwell, J.M. (1985). Receptors and recognition mechanisms of *Leishmania* species. **Trans. R. Soc. Trop. Med. Hyg.** **79**, 606-612.
- Borovsky, D. and Schlein, Y. (1987). Trypsin and chemotrypsin-like enzymes of sandfly *Phlebotomus papatasi* infected with *Leishmania* and their possible role in vector competence. **Medical and Veterinary Entomology** **1**, 235-242.
- Bray, R.S. (1974). *Leishmania*. **Annual Review of Microbiology** **28**, 189-217.

- Bray, R. S. (1987). Experimental leishmaniasis of mammals. **In:** The Leishmaniasis in Biology and Medicine. Volume I. Biology and Epidemiology (Eds, Peters, W. and Killick-Kendrick, R.). Academic Press, London, pp. 425-463.
- Brown, K.S. (1975). The Chemistry of Aphids and Scale Insects. **Chem. Soc. Rev. 4**, 263-288.
- Bryceson, A. (1987). Therapy in man. **In:** The leishmaniasis in Biology and Medicine. Volume II. Clinical Aspects and Control (Eds, Peters, W. and Killick-Kendrick, R.). Academic Press, London, pp 847-907.
- Chance, M.L.; Schnur, L.F.; Thomas, S.C. and Peters W. (1978). The biochemical and serological taxonomy of *Leishmania* from the Ethiopian Zoogeographical region of Africa. **Ann. trop. Med. Parasit. 72**, 533-542.
- Chaniotis, B.H. (1974). Sugar-Feeding Behaviour of *Lutzomyia trapidoi* (Diptera: Psychodidae) under experimental conditions. **J. Med. Ent. 11** (1): 73 -79.
- Chaniotis, B.H. (1986). Successful colonisation of *Lutzomyia trapidoi* (Diptera: Psychodidae) with enhancement of its gonotrophic activity. **J. Med. Entomol. 23** (2): 163-166.
- Chippendale, G.M. (1978). The Functions of Carbohydrates in Insect Life Processes. **In:** Biochemistry of Insects (Ed., Rockstein, M.). Academic Press, New York, pp. 1-55.



- Chogo, J.B. and Crank G. (1981). Chemical composition and biological activity of the Tanzanian plant *Ocimum suave*. **Journal of Natural Products** **44** (3): 308-311.
- Curtis, C.F.; Lines, J.D.; Carnevale, P.; Robert, V.; Boudin, C., Halna, J.M.; Pazart, L.; Gazin, P.; Richard, A.; Mouchet, J.; Chalwood, J.D.; Graves, P.M.; Hossain, M.I.; Kurihara, T.; Ichimori, K.; Zuzi, L.; Badin, L.; Majori G.; Sabatinelli, G.; Coluzzi, M.; Njunwa, K. J.; Wilkes, T. J.; Snow, R.J. and Lindsay, R.W. (1990). Impregnated bed net and curtains against malaria mosquitoes. **In: Appropriate Technology in Vector Control** (Ed., Curtis, C.F.). CRC Press Boca Raton, Florida, 233 pp.
- Dethier, V.G. (1976). The importance of stimulus patterns for host-plant recognition and acceptance. **In: Host-plant in relation to insect behaviour and reproduction** (Ed. Jermy, T.). **Symp. Biol. Hung.** **16**, 76-70.
- Dethier, V.G. (1976). The hungry fly. A physiological study of the behaviour associated with feeding. Harvard University Press, 449 pp.
- Dolmatova, A.V. and Demina, N.A. (1971). Les Phlébotomes (Phlebotominae) et les Maladies qu'ils transmettent. O.R.S.T.O.M., Paris. 168 pp.
- Downes, J.A. (1958). The feeding habits of biting flies and their significance in classification. **A. Rev. Ent.** **3**, 249-266.

- Elliger, C.A. and Waiss, Jr. A. C (1991). Insect resistance factors in *Petunia*. Structure and activity. **In:** Naturally occurring pest bioregulators (Ed., Hedin, P. A.). A C S Symposium Series 449. American Chemical Society. Washington D.C., pp. 210-223.
- Elliot M. Janes N.F. and Potter C. (1978). The future of Pyrethroids in insect control. **Ann. Re. Entomol.** **23**, 443-469.
- Endris R.G., Young D.G. and Butler J.F. (1984). The laboratory biology of *Lutzomyia* (s1p12v1sb4Diptera: Psychodidae). **J. Med. Entomol.** **21** (6): 656-664.
- Endris, R.G.; Young, D.G. and Perkins, P.V. (1987). Experimental transmission of *Leishmania mexicana* by a North American Sandfly, *Lutzomyia anthophora* (Diptera: Psychodidae). **J. Med. Entomol.** **24**, (2): 243-247.
- Engelmann, F. (1984). Reproduction in Insects. **In:** Ecological Entomology (Eds, Huffaker, C.B. and Rabb, L.), John Wiley & Sons. New York, pp. 113-147.
- Evans, D. (1989). Handbook on Isolation, Characterization and Cryopreservation of *Leishmania*. World Health Organization, Geneva, 45 pp.
- Finch, S. (1986). Assessing Host-Plant Finding by Insects. **In:** Insect-Plant Interactions (Eds, Miller, J.R. and Miller, T.A.). Springer-Verlag,. New York, pp. 23-63.

- Garnham, P.C.C.(1987). The Leishmaniasis in Biology and Medicine (Eds, Peters, W. and Killick-Kendrick, R.). Volume I. Biology and Epidemiology. Academic Press, London, pp. viii-xxv.
- Grant, W.D. and Beggs, J.R. (1989). Carbohydrate analysis of beech honeydew. **New Zealand Journal of Zoology** **16** (3): 283-288.
- Green, M. M., Singer, J.M., Sutherland D.J. and Hibben C.R. (1991). Larvicidal activity of *Tagetes minuta* (marigold) toward *Aedes aegypti*. **Journal of the American Mosquito Control Association** **7** (2): 282-286.
- Griffiths, W A.D. (1987). Old World Cutaneous leishmaniasis. **In:** The leishmaniasis in Biology and Medicine. Volume II. Clinical Aspects and Control (Eds, Peters, W. and Killick-Kendrick, R.). Academic Press. London, pp. 617-636.
- Hagen, K.S., Daad, R.H. and Reese, J. (1984). The food of Insects. **In:** Ecological Entomology (Eds, Huffaker, C. B and Rabb, L.). John Willey & Sons, New York, pp. 79-112.
- Hanson, F.E. (1976). Comparative studies on induction of food choice preferences in lepidopteran larvae. **In** Host-plant in relation to insect behaviour and reproduction (Ed., Jermy, T.). **Symp. Biol. Hung.** **16**, 71-77.
- Hassanali, A. and Lwande, W. (1989). Antipest secondary metabolites from African plants. **In:** Insecticides of plant origin. American Chemical Society, Washington D.C., pp. 78-94.

- Hassanali, A.; Lwande, W.; Ole-Sitayo, N.; Moreka, L.; Nokoe, S.; and Chapya, A. (1990). Weevil repellent constituents of *Ocimum suave* leaves and *Eugenia caryophyllata* cloves used as grain protectants in parts of Eastern Africa. **Discovery and Innovation**, 2 (2): 90-95.
- Hawkes, C. and Coaker, T.H. (1976). Behavioural responses to host-plant odours in adult cabbage root fly [*Erioischia brassicae* (Bouché)]. **In:** The host-plant in relation to insect behaviour and reproduction (Ed. Jermy, T.). **Symp. Biol. Hung.** 16, 85-89.
- Hedin, P.A. (1991). Use of Natural Products in Pest Control. **In:** Naturally occurring Pest Bioregulators (Ed., Hedin, P.A. ). ACS Symposium Series 449. American Chemical Society, Washington, D.C., pp. 1-11.
- Hedin, P.A.; Parrot, W.L. and Jenkins, J.N. (1991). Effects of cotton plant allelochemicals and nutrients on behaviour and development of tobacco budworm. **J. Chem. Ecol.** 17 (6): 1107-1112.
- Heisch, R. B.(1963). Is there an animal reservoir of kala-azar in Kenya? **E. Afr. Med. J.** 40, (7): 358-360.
- Huffaker, C.B. Dahlsten, D.L. Janzen, D.H. and Kennedy, G.G. (1984). Insect Influences in The Regulation of Plant Populations and Communities. **In:** Ecological Entomology (Eds, Huffaker, C.B. and Rabb, L). John Willey & Sons, New York, pp. 659-695.

- Ijani, A.S.M. and Mmbaga, M.T. (1988). Studies on the control of root knot nematodes (*Meloidogyne* species) on tomato in Tanzania using marigold plants (*Tagetes* species), ethylene dibromide and aldicarb. **Tropical Pest Management** 34, (2): 147-149.
- Ishaaya, I. (1986). Nutritional and Allelochemic Insect-Plant Interactions Relating to Digestion and Food Intake. **In: Insect-Plant Interactions** (Eds, Miller, J.R. and Miller, T.A.). Springer-Verlag, New York, 342 pp.
- Jermy, T. (1976). Insect-plant relationship: Co-evolution or sequential evolution? **In** The host-plant in relation to insect behaviour and reproduction (Ed., Jermy, T). **Symp. Biol. Hung.** 16, 109-119.
- Jordan, E.M., Waele, D. de and De Waele, D. (1988). Host status of five weed species and their effects on *Practylenchus zae* infestation of maize. **Journal of Nematology**, 20 (4): 620-624.
- Kaddu, J.B. (1986). *Leishmania* in Kenyan Phlebotomine sandflies. III. Advances in the investigations of vectorial capacity and vector-parasite relationships of various species of sandflies in Kenya. **Insect Sci. Applic.** 7 (2): 207-212.
- Kaddu, J.B. and Mutinga, M.J. (1981). *Leishmania* in Kenyan Phlebotomine Sandflies. I. *Leishmania aethiopica* in the midgut of naturally infected *Phlebotomus pedifer*. **Insect Sci. Applic.** 2 (4): 245-250.

- Kaddu, J.B., Mutinga, M. J., Nokoe, S. and Musyoki, R. M. (1992).  
Phytophagy of *Sergentomyia ingrami* I. Feeding rates. **Insect Sci. Applic. 13** (5): 731-735.
- Kaddu, J.B., Mutinga M.J. and Nyamori, M.P. (1986). *Leishmania* in Kenyan Phlebotomine sandflies. IV. Artificial feeding and attempt to infect six species of laboratory-reared sandflies with *Leishmania donovani*.  
**Insect Sci. Applic. 7** (6): 731-735.
- Kamal, R. and Mangla, M. (1987). Toxicity of natural pyrethrins against *Mesocyclops leuckarti* sensu lato, carrier of dracunculiasis [sic].  
**Pyrethrum Post, 16** (4): 125-127).
- Kennedy, S.S. (1977). Olfactory responses to distant plants and other odour sources. **In: Chemical control of Insect behaviour: Theory and application** (Eds, Shorey, H.H and McKelvey, Jr.J.J.). John Wiley & Sons, New York, pp. 67-91.
- Kevan, P.G. and Baker, H.G. (1984). Insects on Flowers. **In: Ecological Entomology** (Eds, Huffaker, C. B. & Rabb, R. L.). John Willey and Sons, New York, pp. 607-631.
- Killick-Kendrick, R. (1979). Biology of *Leishmania* in phlebotomine sandflies.  
**In: Biology of Kinetoplastida Volume 2** (Eds, Lumsden W.H.R. and Evans D.A.), Academic Press, London, pp. 395-449.

Killick-Kendrick, R. (1987). Methods for the study of phlebotomine sandflies.

**In:** The Leishmaniasis in Biology and Medicine. Volume I. Biology and Epidemiology (Eds. Peters, W. and Killick-Kendrick, R.). Academic Press, London, pp. 473-497.

Killick-Kendrick, R. (1990). Phlebotomine vectors of leishmaniasis: a review.

**Medical and Veterinary Entomology** 4, 1-24.

Killick-Kendrick, R. and Killick-Kendrick, M. (1987). Honeydew of aphids as source of sugar for *Phlebotomus ariasi*. **Medical and Veterinary**

**Entomology** 1, 297-302.

Killick-Kendrick, R.; Leaney, A.J. and Ready P.D. (1977). The establishment, maintenance and productivity of a laboratory colony of *Lutzomyia longipalpis* (Diptera: Psychodidae). **J. Med. Ent.** 13 (4-5): 429-440.

Killick-Kendrick, R.; Leaney, A.J.; Ready, P.D. and Molyneux, D.H. (1977).

Leishmaniasis in phlebotomid sandflies. IV. The transmission of *Leishmania mexicana amazonensis* to hamsters by the bite of *Lutzomyia longipalpis*. **Proc. R. Soc. Lond. B.** 190, 105-115.

Kogan, M.(1986). Bioassays for measuring quality of insect food. **In:** Insect-Plant Interactions (Eds, Miller, J.R.and Miller, T.A.). Springer-Verlag, New York, pp. 155-223.

- Lainson, R. and Shaw, J.J. (1979). The role of Animals in the Epidemiology of South American Leishmaniasis. **In:** Biology of the Kinetoplastida. Volume II (Eds, Lumsden, W.H.R. and Evans, D.A.). Academic Press, London, pp 1-196.
- Lainson, R. and Shaw, J.J. (1987). Evolution, classification and geographical distribution. **In:** The Leishmaniasis in Biology and Medicine. Volume I. Biology and Epidemiology (Eds, Peters, W. and Killick-Kendrick R.). Academic Press, London, pp 1-120.
- Lee, S.M.; Clocke, J.A.; Barnby, M.A.; Yamasaki, R.B. and Balandrin, M. F. (1991). Insecticidal constituents of *Azadirachta indica* and *Melia azedarach* (Meliaceae). **In:** Naturally occurring pest bio regulators (Ed., Hedin, P.A.). ACS Symposium Series 449. American Chemical Society, Washington, D.C., pp 293-304.
- Leon, R.B., (1988). Socio-economic dimension of Leishmaniasis. Proceedings of an International Workshop held in Ottawa, Canada 1-4 June 1987, pp 186-189.
- Lewis, D.J. (1982). A taxonomic review of the genus *Phlebotomus* (Diptera:Psychodidae). **Bulletin of the British Museum (Natural History). Entomology Series 45 (2), 121-209.**
- Lewis, D.J. and Domoney, C.R. (1966). Sugar meals in Phlebotominae and Simuliidae (Diptera). **Roy. Entomol. Soc. London 41, 175-179.**



- Lewis, A.C. and van Emden, H.F. (1986). Assays for Insect Feeding. **In:** Insect-Plant Interaction (Eds, Miller, J.R. and Miller, T.A.). Springer-Verlag, New York, pp. 95-119.
- Lewis, D.J. and Ward, R.D. (1987). Transmission and Vectors **In:** The Leishmaniasis in Biology and Medicine. Volume I. Biology and Epidemiology (Eds, Peters, W. and Killick-Kendrick, R.). Academic Press, London, pp. 235-262.
- Lysenko, A.J. and Beljaev, A.E. (1987). Quantitative approaches to epidemiology. **In:** The leishmaniasis in Biology and Medicine. Volume I. Biology and Epidemiology (Eds, Peters, W. and Killick, R.). Academic Press, London, pp. 263-290.
- Ma, W.C. (1976). Mouthparts and receptors involved in feeding behaviour and sugar perception in the African armyworm, *Spodoptera exempta* (Lepidoptera: Noctuidae). **In:** The host plant in relation to insect behaviour and reproduction (Ed., Jermy T.). **Symp. Biol. Hung.** 16, 139-151.
- McFarlane, J.E. (1985). Nutrition and Digestive Organs. **In:** Fundamentals of Insect Physiology (Ed., Blum, M. S.). John Wiley and Sons. New York, pp. 59-89.

- MacVicker, J.A.K.; Moore, J. S.; Molyneux, D. H. and Maroli, M. (1990).  
Honeydew sugars in wild-caught Italian phlebotomine sandflies (Diptera:  
Psychodidae) as detected by high performance liquid chromatography.  
**Bulletin of Entomological Research** **80**, 339-344.
- Magnarelli L.A. and Modi G.B. (1988). Caloric Determinations of Phlebotomine  
Sand Flies (Diptera: Psychodidae). **J. Med. Entomol.** **25** (2): 127-130
- Maxwell, F.G. (1977). Host-plant resistance to insect-chemical relationship.  
**In:** Chemical control of insect behaviour: Theory and application (Eds,  
Shorey, H. H. and McKelvey, Jr.J.J.). John Wiley and Sons, New York,  
pp. 299-304.
- Metcalf, R.L. and Metcalf, E.R. (1992). Plant Kairomones in Insect Ecology  
and Control. Chapman and Hall, New York, ix + 168 pp.
- Mitchell, E.R.; Tingle, F.C. and Heath R.R. (1990). Ovipositional response of  
three *Heliothis* species (Lepidoptera: Noctuidae) to allelochemicals from  
cultivated and wild host plants. **J. Chem. Ecol.** **16**, 1817-1827.
- Modi, G.B. and Tesh R.B. (1983). A simple technique for mass-rearing  
*Lutzomyia longipalpis* and *Phlebotomus papatasi* (Diptera: Psychodidae)  
in the laboratory. **J. Med. Entomol.** **20**, (5): 568-569.
- Moller, H. and Tilley, J.A.V. (1989). Beach honeydew: seasonal variation and  
use by wasps, honeybees and other insects. **New Zealand Journal of  
Zoology** **16** (3): 289-302.

- Molyneux, D.H. and Ashford R.W. (1983). The Biology of *Trypanosoma* and *Leishmania*, Parasites of Man and Domestic Animals. Taylor and Francis, London, viii + 294 pp.
- Molyneux, D.H. and Killick-Kendrick R. (1987). Morphology, ultrastructure and life-cycles. **In:** The Leishmaniasis in Biology and Medicine Volume. I. Biology and Epidemiology (Eds, Peters, W. and Killick-Kendrick, R.). Academic Press. London, pp. 121-176.
- Molyneux, D. H., Killick-Kendrick R. and Ashford R. W. (1975). *Leishmania* in phlebotomid sandflies. III. The ultrastructure of *Leishmania amazonensis* in the midgut and pharynx of *Lutzomyia longipalpis*. **Proc. R. Soc. Lond. B.** 190, 341-357.
- Moore, J.S.; Kelly, T.B.; Killick-Kendrick, R.; Killick-Kendrick, M.; Wallbanks, K.R. and Molyneux, D.H.(1987). Honeydew sugars in wild-caught *Phlebotomus ariasi* detected by high performance liquid chromatography (HPLC) and gas chromatography (GC). **Medical and Veterinary Entomology** 1, 427-434.
- Mutinga, M.J. (1986). Epidemiology of Leishmaniasis in Kenya. Advances in research on vectors and animal reservoirs, and possible control measures. **Insect Sci.Applic.** 7, (2): 199-206.
- Mutinga, M.J. (1986). Leishmaniasis. **Insect Sci.Applic.** 7 (2): 421-427.

- Mutinga, M.J. (1988). Leishmaniasis. **Proceedings of an International Workshop held in Ottawa, Canada**, 1-4 June 1987, pp. 24-36.
- Mutinga, M.J. (1991). A review on investigations on leishmaniasis vectors in Kenya. **Parasitologia**, **33** (Suppl. 1), 453-461.
- Mutinga, M.J.; Basimike, M.; Mutero, C. M. and Ngindu, A. M. (1992). The use of permethrin-impregnated wall cloth (Mbu cloth) for control of vectors of malaria and leishmaniasis in Kenya. II. Effect on sandflies populations. **Insect Sci. Applic.** **13** (2): 163-172.
- Mutinga, M.J.; Kaddu, J.B. and Irungu, L.W.(1981). Animal models for feeding Kenyan wild-caught Phlebotomine sandflies (Diptera: Phlebotomidae). **Insect Sci.Applic.2** (3): 149-152.
- Mutinga, M.J.; Kamau, C.C.; Kaddu, J.B.; Kyai, F.M.; Omogo, D.M.; Mwandandu, J. and Ndambuki, J. (1989). The biology and colonization of some Kenyan Phlebotomine sandfly species (Diptera: Psychodidae). **Insect Sci. Applic.** **10** (5): 677-683.
- Mutinga, M.J., Kamau, C.C. and Kyai, F.M. (1986). Investigations on the Epidemiology of Leishmaniasis in Kenya. IV. Breeding habitat of *Phlebotomus duboscqi* (Diptera: Psychodidae), a vector of *Leishmania major* in Marigat, Baringo District, Kenya. **Insect Sci. Applic.** **7** (6): 726-729.

- Mutinga, M.J.; Kamau, C.C. and Mwandandu, J. (1987). Laboratory investigations on the survival and fecundity of *Phlebotomus duboscqi* (Diptera: Psychodidae), a vector of *Leishmania major* in Kenya. **Trop. Med. Parasit.** **38**, 86-88.
- Mutinga, M J.; Kyai, F. M.; Kamau, C.C. and Omogo, D.M. (1986). Epidemiology of Leishmaniasis in Kenya. III. Host preference studies using various types of animal baits at animal burrows in Marigat, Baringo District. **Insect Sci. Applic.** **7** (2): 191-197.
- Mutinga, M.J.; Mutero, C. M.; Basimike, M. and Ngindu, A.M. (1992). The use of permethrin impregnated wall cloth (Mbu cloth) for control of vectors of malaria and leishmaniasis in Kenya. I. Effects on mosquito populations. **Insect Sci. Applic.** **13** (2): 151-162
- Neal, R. A. (1987). Experimental Chemotherapy. **In: The leishmaniasis in Biology and Medicine. Volume II. Clinical Aspects and Control** (Eds, Peters., W. and Killick-Kendrick., R.). Academic Press, London, pp. 793-845.
- Noad, T. and Birnie, A. (1990). Trees of Kenya. Noad and Birnie, Publishers, Nairobi, 299 pp.
- Nottingham, S.F.; Hardie J.; Dawson C.W.; Hick A.J.; Richkett, J.A.; Wadhams, L.J. and Woodcock, C.M. (1991). Behavioural and electrophysiological responses of aphids to host and non-host plant volatile. **J. Chem. Ecol.** **17**, 1231- 1242.

- Opp, S.B. and Prokopy, R.J. (1986). Approaches and Methods for Direct Behavioural Observation and Analysis of Plant-Insect Interactions. **In** Insect-Plant Interactions (Eds, Miller J.R. and Miller T.A.). Springer-Verlag, New York, pp. 1-22.
- Oster, C.N. (1986). Advances in clinical diagnosis and chemotherapy of Leishmaniasis in Kenya. **Insect Sci. Applic.** 7 (2): 235-240.
- Paton A. (1991). A synopsis of *Ocimum* L. (Labiatae). **Kew Bulletin** 47 (3): 403-437.
- Paxton J.D. (1991). Phytoalexins and their Potential Role in Control of Insect Pests. **In: Naturally occurring Bioregulators** (Ed., Hedin, P.A). ACS Symposium Series 449. American Chemical Society, Washington, D.C., pp. 198-207.
- Perkins, P.V.; Lawyer, P.G.; Rowton, E.D. and Johnson, R.R. (1991). Recent Advances in Laboratory Mass Rearing of Phlebotomine Sand flies. Working paper. Workshop. Department of Entomology, Division of Communicable Diseases and Immunology, Walter Reed Army Institute of Research. Washington D.C. 20307-5100.
- Peters, W. (1979). Les Leishmanioses. Royal Tropical Institute, Amsterdam, 28 pp., 84 microfilms.

- Pozio, E., Maroli, M.; Gradon, L. and Gramiccia M. (1985). Laboratory transmission of *Leishmania infantum* to *Rattus rattus* by bite of experimentally infected *Phlebotomus perniciosus*. **Trans. Roy.Soc.Trop.Med.Hyg.79**, 524-526.
- Raadt, P. de (1986). Leishmaniasis. I. Global Impact on Health. **Insect Sci. Applic. 7 (2)**: 155-156.
- Rees, P.H. and Kager, P.A. (1987). Visceral and post-kala-azar dermal leishmaniasis. **In** Leishmaniasis in Biology and Medicine. Volume II. Clinical Aspects and control (Eds, Peters W. and Killick-Kendrick R.). Academic Press, London, pp. 583-615.
- Ridley D.S. (1987). Pathology. **In**: Leishmaniasis in Biology and Medicine. Volume II. Clinical Aspects and Control.(Eds, Peters, W. and Killick-Kendrick, R.) Academic Press, London, pp. 665-701.
- Rejesus, B. M. (1990). Botanical pesticides in integrated pest management. National Conference and Workshop on Integrated Pest Management in Rice, Corn and selected Major Crops. College, Lagune (Philippines), 23 pp.
- Rembold, H.; Foster, H.; Czoppelt, Ch.; Rao, P.J. and Sieber, K.P. (1984). The azadirachtins, a group of insect growth regulators from the neem tree. **In**: Natural pesticides from the neem tree and other tropical plants. Proc. 2nd Int. Neem Conf. Rauschholzhausen, 1983, 153-162.

- Robacker, D.C.; Moreno, T.A.M.; Garcia, J.A. and Flath, R.A. (1990). A novel attractant for Mexican fruit fly, *Anastrepha ludens* from fermented host fruit. **J. Chem. Ecol.** **16**, (10): 2799-2815.
- Sacks, D.L. and Perkins, P.V. (1984). Identification of an Infective Stage of *Leishmania* Promastigotes. *Science* **233**, (4643): 1417-1419.
- Scheurer, S. (1976). The influence of phytohormones and growth regulating substances on insect development processes. In: The host-plant in relation to insect behaviour and reproduction (Ed., Jermy, T.). **Symp. Biol. Hung.** **16**, 255-259.
- Schlein, Y. (1986). Sandfly diet and *Leishmania*. **Parasitology Today**, **2** (6): 175-177.
- Schlein, Y. (1987). Marking of *Phlebotomus papatasi* (Diptera: Psychodidae) by feeding on sprayed, coloured sugar baits: A possible means for behavioural and control studies. **Trans. R. Soc. Trop. Med. Hyg.** **81**, 599.
- Schlein Y. (1988). Recent observations on factors affecting the life cycles of Leishmaniae in the sandfly. Proceedings of International Workshop held in Ottawa, Canada, 1-4 June 1987; pp. 299-301.
- Schlein, Y. (1993). *Leishmania* and Sandflies: Interactions in the Life cycle and Transmission. **Parasitology Today** **9** (7): 255-257.



- Schlein, Y.; Mutinga, M.J.; Jacobson, R.L. and Kaddu, J.B. (1990). Evaluation of food dye marking in the study of sandfly behaviour in Baringo District, Kenya. **Insect Sci. Applic.** **11** (1): 91-96.
- Schlein, Y. and Warburg, A. (1985). Feeding behaviour, midgut distension and ovarian development in *Phlebotomus papatasi* (Diptera: Psychodidae). **J. Insect. Physiology.** **31** (1): 47-51.
- Schlein, Y. and Warburg A. (1986). Phytophagy and feeding cycle of *Phlebotomus papatasi* (Diptera: Psychodidae) under experimental conditions. **J. Med. Entomol.**, **23** (1): 11-15.
- Schlein, Y.; Warburg, A. and Yuval B. (1986). On the system by which sandflies maintain a sterile gut. **Insect Sci. Applic.** **7** (2): 231-234.
- Schlein, Y. and Yuval, B. (1987). Leishmaniasis in the Jordan Valley. IV. Attraction of *Phlebotomus papatasi* (Diptera: Psychodidae) to plants in the field. **J. Med. Entomol.** **24**,1: 87-90.
- Schlein, Y.; Yuval.; B and Jacobson, R. L. (1989). Leishmaniasis in Jordan Valley: Differential Attraction of Dispersing and Breeding Site Population of *Phlebotomus Papatasi* (Diptera: Psychodidae) to Manure and Water. **J. Med. Entomol.** **26** (5): 411-413.

- Schmutterer, H. (1987). Fecundity-reducing and sterilizing effects of neem seed kernel extracts in Colorado potato beetle, *Leptinotarsa decemlineata*. In: Natural pesticides from the neem tree (*Azadirachta indica* A.Juss) and other tropical plants. Proc. 3rd Int. Neem Conf., Nairobi, 1986, pp. 351-360.
- Schmutterer, H. and Zebitz, C.P.W. (1984). Effects of methanolic extracts from seeds of single neem trees of African and Asian origin, on *Epilachna varivestris* and *Aedes aegypti*. In: Natural pesticides from the neem tree and other tropical plants. Proc. 2nd Int. Neem Conf. Rauschholzhausen, 1983, pp. 83-90.
- Schoonhoven, L. M. (1977). Insect chemosensory response to plant and animal hosts. In: Chemical control of insect behaviour: Theory and application (Eds, Shorey H.H. and McKelvey Jr.J.J.). John Wiley & Sons, New York, pp. 7-14.
- Shaw, J.J. and Lainson, R. (1987). Ecology and Epidemiology: New World. In: The Leishmaniasis in Biology and Medicine Vol. I. Biology and Epidemiology (edited by Peters W. and Killick-Kendrick, R.J. London, UK. Academic Press, London, pp. 291-363.
- Shorey, H.H. (1977). Interaction of insects with chemical environment. In: Chemical control of insects behaviour: Theory and application (Eds, Shorey, H.H. and McKelvey, Jr. J.J.). John Wiley & Sons, New York, pp. 1-5.

- Siddiqui, M A. and Alam, M.M. (1988). Studies on the nemato-toxicity of root-exudates of certain species of *Tagetes*. *Indian Journal of Nematology*. 18, 2: 335-337.
- Singer, M.C. (1986). The definition and measurement of oviposition preference in plant-feeding insects. **In:** *Insect-plant interactions* (Eds, Miller, J.R. and Miller, T.A.). Springer-Verlag, New York, pp. 65-94.
- Smith, C M. (1989). *Plant resistance to insects: A fundamental approach*. John Wiley & Sons, New York, 286 pp.
- Strong, D.R.; Lawton, J.H. and Southwood, S.R. (1984). *Insects on plants*. Blackwell Scientific Publications, Oxford, vi + 313 pp.
- Thompson, J.N. (1984). *Insect Diversity and Trophic Structure of Communities*. **In:** *Ecological Entomology* (Eds, Huffaker, C.B. & Rabb, R.L.). John Wiley & Sons, New York, pp. 591-606.
- Tingey, W.M. (1991). Potato glandular trichomes. Defensive activity against insect attack. **In:** *Naturally occurring pest bioregulators* (Ed. Hedin, P.A.). ACS Symposium Series 449. American Chemical Society, Washington, D.C. pp. 126-135.
- Tingle F.C.; Heath; R.R. and Mitchell, E.R. (1989). Flight response of *Heliothis subflexa* (Gn) females (Lepidoptera: Noctuidae) to an attractant from groundcherry, *Physalis angulata* L. **J. Chem. Ecol.** 15 (1):221-231.

- Tingle, F.C.; Mitchell E.R. and Heath R.R. (1990). Preferences of mated *Heliophilis viescens* and *H. subflexa* females for host and non-host volatiles in a flight tunnel. **J. Chem. Ecol.**, **16**, (10): 2889-2899.
- Titus, R.G. and Ribeiro J.M.C. (1988). Salivary Gland Lysates from the Sand Fly *Lutzomyia longipalpis* Enhance *Leishmania* Infectivity. **Science** **239**, 1306-1308.
- Titus R.G. and Ribeiro J.M.C. (1990). The role of Vector Saliva in Transmission of Arthropod-Borne Disease. **Parasitology Today** **6** (5): 157-160.
- Van Handel E. (1972). Detection of Nectar in Mosquitoes. **Mosquito News** **32** (3): 558-559.
- Vioukov, V.N. (1987). Control of Transmission. **In: The Leishmaniases in Biology and Medicine Volume II. Clinical Aspects and Control** (edited by Peters W. and Killick-Kendrick R.). Academic Press. London, pp. 909-928.
- Waldbauer G.P. and Friedman, S. (1991). Self-selection of optimal diets by insects. **Ann. Rev. Entomol.** **36**, 43-63.
- Walton B.C. (1984). Application of Biochemical and Molecular Biology Techniques to Problems of Identification and Taxonomy of *Leishmania*. **In: New Approaches to Identification of Parasites and their Vectors** (Eds, Schwabe & AG). Basel, pp. 277-292.

Walton B. C. (1987). American cutaneous and mucocutaneous leishmaniasis.

In: The Leishmaniasis in Biology and Medicine Volume II. Clinical Aspects and Control (Eds, Peters, W. and Killick-Kendrick, R.). Academic Press, London, pp. 637-664.

Walton, B.C. (1988). Leishmaniasis. A global Problem. Proceedings of an International Workshop held in Ottawa, Canada, 1-4 June 1987, pp 1-7.

Watt, J. M. and Breyer-Brandwijk, M. G. (1962). The medical and poisonous plants of Southern and Eastern Africa. 2nd Ed. E.& S. Livingston LTD. Edinburgh and London, xii + 1457 pp.

Were, J., Muigai, R., Wasunna K., Rashid J.R. and Oster C.N. (1986).

Chemotherapy of Leishmaniasis. **Insect Sci. Applic.** 7 (3): 421-427.

WHO/Special Programme for Research and Training in Tropical Diseases (TDR) (1990). Tropical Diseases in Media Spotlight. TDR News, No. 31.

WHO/Special Programme for Research and Training in Tropical Diseases (TDR) (1990). Antimonials: large scale failure "alarming". TDR News, No. 34.

WHO/Special Programme for Research and Training in Tropical Diseases (TDR) (1991). Kala-azar surges on two fronts. TDR News, No. 37.

- Wijers, D.J.B. (1971). A ten years study of Kala-azar in Tharaka (Meru District, Kenya). Part II. Relapses. **E. Afr. Med. J.** **48**, 551-558.
- Yoshida, S.; Forno D.A.; Cock J.H. and Gomez K. A. (1976). Laboratory Manual for Physiological Studies of Rice. The International Rice Research Institute, Los Banos, 59 pp.
- Young, C.J.; Turner D.P.; Killick-Kendrick R.; Rioux J.A. and Leaney, A.J. (1980). Fructose in wild-caught *Phlebotomus ariasi* and possible relevance of sugars taken by sandflies to transmission of Leishmaniasis. **Trans. Roy. Soc. Trop. Med. Hyg.** **74** (3): 363-366.
- Yuval, B.; Warburg, A. and Schlein, Y. (1988). Leishmaniasis in Jordan Valley. V. Dispersal characteristics of the sandfly *Phlebotomus papatasi*. **Medical and Veterinary Entomology** **2**, 391-395.
- Zmur, V. and Sary, P. (1992). Field experiments with different attractants in baited pitfall traps for *Hylobius abietes* (Coleoptera: Curculionidae). **J. Appl. Entomol.** **113** (5): 4451-455.

## APPENDICES

### Appendix 1:

Feeding rates of *S. ingrami* on different plant species, sucrose and water.

Diet	ND	% (Mean $\pm$ SE)
Ai	288	42.71 $\pm$ 2.06b
Ma	288	56.60 $\pm$ 3.61a
Ok	288	20.83 $\pm$ 3.08d
Os	288	11.81 $\pm$ 3.32e
Ru	288	60.74 $\pm$ 4.11a
Si	288	29.51 $\pm$ 3.01c
Tm	288	2.72 $\pm$ 0.62f
Su	288	55.21 $\pm$ 0.78b
Wa	288	0.00 $\pm$ 0.00f

Ai: *A. indica*; Ma: *M. azedarach*; Ok: *O. kenyense*; Os: *O. suave*;  
Ru: *R. usambarensis*; Si: *S. incanum*; Tm: *T. minuta*; Su: Sucrose; Wa: Water;  
ND: Number of flies dissected;  
Means followed by the same letter are not significantly different at  $P \geq 0.05$ ;  
SE: Standard error.

Appendix 2:

Feeding rates of *P. duboscqi* on different plant species, sucrose and water.

Diet	ND	% (Mean $\pm$ SE)
Ai	288	29.17 $\pm$ 4.38d
Ma	288	82.97 $\pm$ 3.64a
Ok	288	17.01 $\pm$ 3.05e
Os	288	9.37 $\pm$ 2.24f
Ru	288	55.56 $\pm$ 1.94c
Si	288	26.29 $\pm$ 1.73d
Tm	288	1.39 $\pm$ 0.59g
Su	288	70.49 $\pm$ 3.14b
Wa	288	0.35 $\pm$ 0.35g

Ai: *A. indica*; Ma: *M. azedarach*; Ok: *O. kenyense*; Os: *O. suave*;  
Ru: *R. usambarensis*; Si: *S. incanum*; Tm: *T. minuta*; Su: Sucrose; Wa: Water;  
ND: Number of flies dissected;  
Means followed by the same letter are not significantly different at  $P \geq 0.05$ ;  
SE: Standard error.



**Appendix 3:**

**Effect of specific diet on the feeding performance of *S. ingrami* on different on plant species and sucrose.**

**Analysis of variance.**

Source (diet)	Blue colour intensity level		
	D	M	F
DF	7	7	7
MS	134.523	671.709	1702.809
F-value	9.59	12.140	14.340
P > F	0.0001**	0.0001**	0.0001**

DF: Degree of freedom; MS: Mean square; F: Fisher's index; P: Probability; \*\*: Highly significant difference; D: Deep; M: Medium; F: Faint.

**Appendix 4:**

**Effect of specific diet on the feeding performance of *P. duboscqi* on different plant species and sucrose.**

**Analysis of variance.**

Source (diet)	Blue colour intensity level		
	D	M	F
DF	7	7	7
MS	1505.043	1070.448	2098.111
F-value	32.26	24.84	23.032
P > F	0.0001**	0.0001**	0.0001**

DF: Degree of freedom; MS: Mean square; F: Fisher's index; P: Probability; \*\*: Highly significant difference; D: Deep; M: Medium; F: Faint.

**Appendix 5:**

**Effect of temperature on the optical density of three standard sugars after test with anthrone.**

**Analysis of variance.**

Source (temperature)	Standard sugar		
	Fructose	Glucose	Sucrose
DF	1	1	1
MS	0.00009	0.111	0.00008
F-value	0.03	6.06	0.04
P > F	0.87 <sup>NS</sup>	0.008 <sup>*</sup>	0.84 <sup>NS</sup>

DF: Degree of freedom; MS: Mean square; F: Fisher's index; P: Probability; NS: Difference not significant; \*: Significant difference.

**Appendix 6:**

**Effect of plant species on sugar concentration in water extracts from fresh plant materials tested by cold anthrone.**

**Analysis of variance.**

Source (plant)	Standard sugar		
	Fructose	Glucose	Sucrose
DF	6	6	6
MS	0.3199	20.8493	0.4479
F-value	58.68	43.58	37.10
P > F	0.0001 <sup>**</sup>	0.0001 <sup>**</sup>	0.0001 <sup>**</sup>

DF: Degree of freedom; MS: Mean square; F: Fisher's index; P: Probability; \*\*: Highly significant difference.

**Appendix 7:**

**Effect of plant species on the concentration (three equivalents) in water extracts from fresh plant materials tested with hot anthrone.**

**Analysis of variance.**

Source (plant)	Sugar equivalent		
	Fructose	Glucose	Sucrose
DF	6	6	6
MS	0.5318	36.5339	0.8098
F-value	2120.24	2021.41	1796.80
P > F	0.0001**	0.0001**	0.0001**

DF: Degree of freedom; MS: Mean square; F: Fisher's index; P: Probability;  
\*\*: Highly significant difference.

**Appendix 8:**

**Effect of plant species on sugar concentration (three equivalents) in water extracts from plant materials subjected to sequential extraction and treated with hot anthrone.**

**Analysis of variance.**

Source (plant)	Sugar equivalent		
	Fructose	Glucose	Sucrose
DF	6	6	6
MS	36.2003	660.0925	65.9906
F-value	79.32	61.33	67.20
P > F	0.000**	0.0001**	0.0001**

DF: Degree of freedom; MS: Mean square; F: Fisher's index; P: Probability;  
\*\*: Highly significant difference.

**Appendix 9:**

**Effect of diet on the developmental duration of the immature stage of the progeny of *S. ingrami* females maintained, after blood meal, on *R. usambarensis*, *S. incanum*, sucrose and water.**

**Analysis of variance.**

Source (diet)	Instar <sub>1</sub>	Instar <sub>2</sub>	Instar <sub>3</sub>	Instar <sub>4</sub>	Pupa
DF	3	3	3	3	3
MS	3.135	0.009	0.093	0.178	21.712
F-value	0.14	0.008	0.29	0.14	0.04
P > F	0.93 <sup>NS</sup>	0.97 <sup>NS</sup>	0.83 <sup>NS</sup>	0.93 <sup>NS</sup>	0.98 <sup>NS</sup>

DF: Degree of freedom; MS: Mean square; F: Fisher's index;  
P: Probability; NS: Difference not significant.

**Appendix 10:**

**Effect of diet on the duration of the main developmental stages/periods in the life cycle of *S. ingrami* when females were maintained on *R. usambarensis*, *S. incanum*. sucrose and water during the pre-oviposition period.**

**Analysis of variance.**

Source (diet)	Developmental stage/period					
	Oogenesis	Embryonation	Larva	Pupa	Embry-Emerg	Oogen-Emerg
DF	3	3	3	3	3	3
MS	0.186	0.092	0.307	21.712	0.545	0.901
F-value	0.32	0.26	0.06	0.04	0.03	0.10
P > F	0.81NS	0.85NS	0.98NS	0.98NS	0.99NS	0.96NS

DF: Degree of freedom; MS: Mean square; F: Fisher's index; P: Probability; NS: Difference not significant.  
Embry: Embryonation; Oogen: Oogenesis; Emerg: Emergence.

Appendix 11:

Survival of developmental stages of the progeny, with reference to eggs, when *S. ingrami* females were maintained on different diets during the pre-oviposition period.

Diet	Number and % rate (Mean $\pm$ SE) by stage			
	Eggs	Larvae	Pupae	Adults
Ru	8990	62.24 $\pm$ 5.39a (5685)	52.78 $\pm$ 4.61a (4745)	37.96 $\pm$ 3.85a (3413)
Si	7128	57.87 $\pm$ 3.76a (4125)	45.95 $\pm$ 3.42a (3275)	32.15 $\pm$ 5.40a (2292)
Su	9584	63.69 $\pm$ 3.88a (6104)	50.64 $\pm$ 5.08a (4853)	34.16 $\pm$ 3.18a (3274)
Wa	8746	57.76 $\pm$ 4.89a (5052)	43.81 $\pm$ 4.82a (3832)	31.21 $\pm$ 4.92a (2730)

Ru: *R. usambarensis*; Si: *S. incanum*; Su: Sucrose; Wa: water;

() : Number by stage;

Vertical means followed by the same letter are not significantly different at  $P \geq 0.05$ ;

SE: Standard error.

**Appendix 12:**

**Effect of diet on reproductivity of females and developmental survival of the progeny in *S. ingrami* when the former were maintained on *R. usambarensis*, *S. incanum*, sucrose and water during the pre-oviposition period.**

**Analysis of variance.**

Source (diet)	OR	FR	HR	PR	TR	SR	ER
DF	3	3	3	3	3	3	3
MS	94.288	208.57	14.245	24.490	128.892	3.901	99.277
F-value	0.58	0.99	0.39	0.86	3.39	0.74	2.45
P > F	0.64NS	0.42NS	0.77NS	0.48NS	0.04*	0.54	0.04*

DF: Degree of freedom; MS: Mean square; F: Fisher's; P: Probability;  
 OR: Oviposition rate; FR: Fecundity rate; HR: Hatching rate; PR: Pupation rate; TR: Total reproductive rate; SR: Sex-ratio;  
 ER: Effective reproductive rate;  
 NS: Difference not significant; \*: Significant difference.



**Appendix 13:**

**Effect of diet on the developmental duration of immature stages of the progeny when *P. duboscqi* females were maintained on *R. usambarensis*, *S. incanum*; sucrose and water.**

**Analysis of variance.**

Source (diet)	Instar <sub>1</sub>	Instar <sub>2</sub>	Instar <sub>3</sub>	Instar <sub>4</sub>	Pupa
DF	3	3	3	3	3
MS	0.385	0.191	0.171	0.667	1.049
F-value	1.62	1.16	0.46	1.10	1.39
P > F	0.22NS	0.36NS	0.71NS	0.38NS	0.28NS

DF: Degree of freedom; MS: Mean square; F: Fisher's index; P: Probability; NS: Difference not significant.

**Appendix 14:**  
**Effect of diet on the duration of the main stages/periods of the life cycle of *P. duboscqi* when females were maintained on *R. usambarensis*, *S. incanum*, sucrose and water during the pre-oviposition period.**

**Analysis of variance.**

Source (diet)	Developmental stage/period							
	Oogenesis	Embryonation	Larva	Pupa	Embry-Emerg	Oogen-Emerg		
DF	3	3	3	3	3	3		
MS	2.19	0.02	0.19	1.05	4.86	4.52		
F-value	3.44	0.18	1.16	1.39	1.48	1.67		
P > F	0.04*	0.91 <sup>NS</sup>	0.36 <sup>NS</sup>	0.29 <sup>NS</sup>	0.26 <sup>NS</sup>	0.21 <sup>NS</sup>		

DF: Degree of freedom; MS: Mean square; F: Fisher's index; P: Probability; \*: Significant difference; NS: Difference not significant;  
 Oogen: Oogenesis; Embry: Embryonation; Emerg: Emergence.

**Appendix 15:**

**Effect of diets on the developmental survival during the immature stage of the progeny in *P. duboscqi* when females were maintained on *R. usambarensis*, *S. incanum*, sucrose and water during the pre-oviposition period.**

**Analysis of variance.**

Source (diet)	Instar <sub>1</sub>	Instar <sub>2</sub>	Instar <sub>3</sub>	Instar <sub>4</sub>	Pupae
DF	3	3	3	3	3
Ms	14.6493	0.0009	0.0005	0.0014	0.006
F-value	0.11	0.0048	0.27	0.88	0.66
P > F	0.95NS	0.70NS	0.85NS	0.17NS	0.59NS

DF: Degree of freedom; MS: Mean square; F: Fisher's index; P: Probability; NS: Difference not significant.

**Appendix 16:**

**Effect of diet on the reproductivity of parental females and developmental survival of the progeny in *P. duboscqi* when the former were maintained on *R. usambarensis*, *S. incanum*, sucrose and water during the pre-oviposition period.**

**Analysis of variance.**

Source (diet)	OR	FR	HR	PR	TR	SR	ER
DF	3	3	3	3	3	3	3
MS	16.57	1015.99	14.831	23.567	38.607	21.290	9.150
F-value	2.18	2.86	0.11	1.37	1.80	4.34	2.29
P > F	0.13NS	0.04*	0.95	0.29NS	0.19NS	0.02*	0.12NS

DF: Degree of freedom; MS: Mean square; F: Fisher's index; P: Probability; NS: No significant difference; \*: Significant difference; OR: Oviposition rate; FR: Fecundity rate; HR: Hatching rate; PR: Pupation rate; SR: Sex-ratio; ER: Effective reproductive rate.

Appendix 17:

Survival of the developmental stages of the progeny, with reference to eggs, when *P. duboscqi* females were maintained on different diets during the pre-oviposition period.

Diet	Number and % rate (Mean $\pm$ SE) by stage			
	Eggs	Larvae	Pupae	Adults
Ru	5835	57.62 $\pm$ 3.48a (3362)	43.05 $\pm$ 3.26a (2512)	36.86 $\pm$ 3.05a (2151)
Si	5291	57.47 $\pm$ 3.80a (3041)	43.17 $\pm$ 5.02a (2284)	32.83 $\pm$ 6.50a (1737)
Su	5959	55.05 $\pm$ 6.92a (3281)	38.13 $\pm$ 4.32a (2272)	27.37 $\pm$ 2.90a (1631)
Wa	5103	58.18 $\pm$ 5.53a (2969)	39.49 $\pm$ 3.90a (2013)	30.81 $\pm$ 7.07a (1572)

Ru: *R. usambarensis*; Si: *S. incanum*; Su: Sucrose; Wa: Water;

() : Number/stage/diet;

Vertical means followed by the same letter are not significantly different at  $P \geq 0.05$ ; SE: Standard error.